



PARTS LIST FOR
AIR COMPRESSOR
AM1-HE02-05M

PHASE:	Single
VOLTS:	115
MAXIMUM AMPS:	15
MAXIMUM PRESSURE:	125 PSI
COMPRESSOR OIL GRADE:	SAE30W Non-Detergent
COMPRESSOR OIL CAPACITY:	7.0 oz.

This Parts Listing has been compiled for your benefit. You can be assured your Mi-T-M Electric Air Compressor was constructed and designed with quality and performance in mind. Each component has been rigorously tested to insure the highest level of acceptance.

The contents of this Parts Listing are based on the latest product information available at the time of publication. Mi-T-M reserves the right to make changes in price, color, materials, equipment, specifications or models at any time without notice.

WARNING

THIS IS A PROFESSIONAL ELECTRIC AIR COMPRESSOR. CAUTION SHOULD BE OBSERVED WHEN USING OR REPAIRING THIS UNIT! READ AND FOLLOW THE SAFETY WARNINGS LISTED BELOW BEFORE ATTEMPTING ANY REPAIRS ON THIS ELECTRIC AIR COMPRESSOR!

SAFETY WARNINGS

1. NEVER alter or modify the equipment. Be sure any accessory items and system components being used will withstand the pressure developed. Serious injury may occur from an air compressor malfunction or exploding accessories if incorrect system components, attachments or accessories are used. NEVER exceed manufactures maximum allowable pressure rating of attachments. Use only genuine Mi-T-M parts for repair of your air compressor. Failure to do so can cause hazardous operating conditions and will VOID warranty.
2. Know how to stop and bleed pressures quickly. Be thoroughly familiar with controls. Do not operate without protective covers/ guards.
3. Before servicing the unit, turn unit off, relieve the pressure and unplug the air compressor from the power source. Allow the unit to cool down. NEVER assume the air compressor is safe to work on just because it is not operating. It could restart at any time! Service in a clean, dry, flat area. Block the wheels to prevent the unit from moving. Be especially careful to properly dispose of any flammable materials.
4. After testing the machine, DO NOT leave the pressurized unit unattended. Shut off the unit and pressure before leaving.

TABLE OF CONTENTS

SPECIFICATIONS	3
TANK ASSEMBLY FOR AM1-HE02-05M	4
COMPRESSOR/MOTOR ASSEMBLY (3-0395).....	6

SPECIFICATIONS

MODEL NUMBER	AM1-HE02-05M
Motor:	
Horsepower	2.0
Voltage	115
Amperage	15
Hz	60
Phase	Single
Motor RPM	3420
Compressor Pump:	
Number of Cylinders	1
Compression Stages	1
Bore/Stroke	1.96" x 1.33"
Compression RPM	3400
Lubrication	Splash
Oil Quantity	7 oz.
Oil Type	SAE30W Non-Detergent
Crankcase	Aluminum
Bearings	Ball
Cylinder	Cast Iron
Valves	Reed
Head	Aluminum
Filter	Canister
Pilot Valve Setting:	
Cut-out	125 PSI
Cut-in	95 PSI
Air Tank:	
Capacity	5 Gallons
Performance:	
CFM Air Displacement	8.13
CFM @ 40 PSI	5.3
CFM @ 100 PSI	4.0
Maximum Pressure	125 PSI
Pump-up Time: 0-125 PSI	93 seconds
Recovery Time: 90-125 PSI	14 seconds
Working Pressure Range	95-125 PSI
Weight:	
Net	60 lbs
Shipping	69 lbs
Dimensions:	
Basic L x W x H	20.5" x 15.5" x 17.5"
Shipping L x W x H	20.5" x 16.5" x 20"

TANK ASSEMBLY FOR AM1-HE02-05M

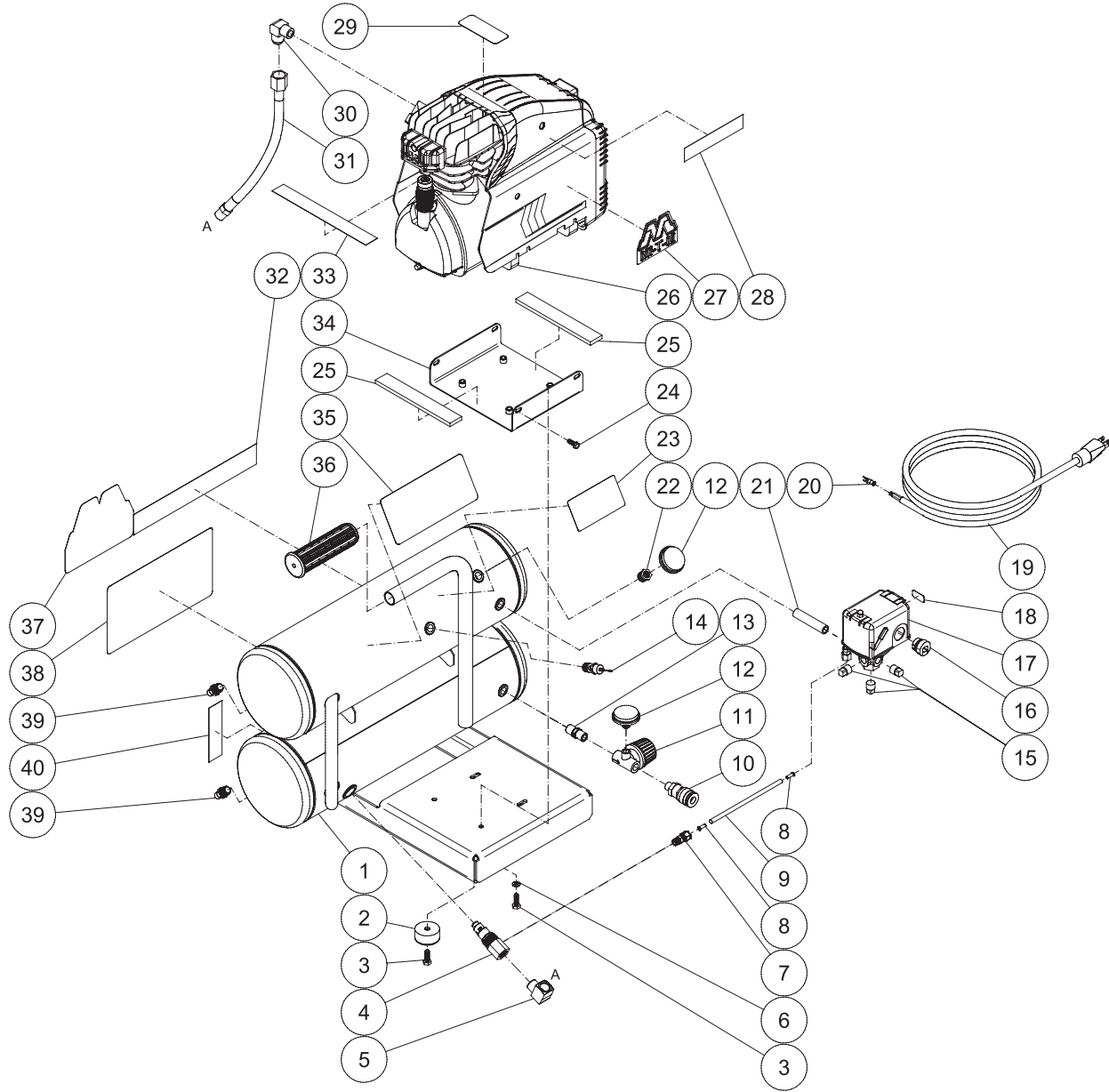

TANK ASSEMBLY			
ITEM	DESCRIPTION	PART #	QTY
1	5 GALLON TWIN TANK	12-0152A01	1
2	ISOLATOR	14-0069	4
3	BOLT	27-0015	8
4	CHECK VALVE	22-0334	1
5	ELBOW	23-0034	1
6	LOCKWASHER	29-0006	4
7	ADAPTER	23-0328	1
8	TUBE SUPPORT	23-0486	2
9	HOSE *(TWO FEET REQUIRED)	15-0238	1
10	AIR QC SOCKET	17-0043	1
11	REGULATOR	22-0326	1
12	PRESSURE GAUGE	22-0257	2
13	NIPPLE	24-0145	1
14	SAFETY VALVE	22-0228	1
15	PLUG	23-0238	3
16	BUSHING	9-0045	2
17	PRESSURE SWITCH	22-0397	1
18	DECAL - 115 VOLT (SEE 71-2000)	N/A	1
19	CORD PLUG SET	32-0444	1
20	TERMINAL	32-0003	3
21	NIPPLE	24-0314	1
22	REDUCER	23-0111	1
23	DECAL- SILVER STICKER	N/A	1
24	BOLT	27-8390	4
25	FOAM PAD *(ONE FOOT REQUIRED)	26-0289	2
26	MOTOR/PUMP	3-0395	1
27	DECAL - #2M (SEE 71-2000)	N/A	1
28	DECAL - HORSEPOWER (SEE 71-2000)	N/A	1
29	DECAL - RISK OF BURNS (SEE 71-2000)	N/A	1
30	ELBOW	23-0426	1
31	HOSE	15-0237	1
32	DECAL - 10.5" LONG STRIPE (SEE 71-2000)	N/A	1
33	DECAL - CHECK OIL	N/A	1
34	PUMP SUPPORT BRACKET	13-0138A01	1
35	DECAL - OPERATING INSTRUCTIONS (SEE 71-2000)	N/A	1
36	HANDLE GRIP	7-0059	1
37	DECAL - Mi-T-M	34-2169	1
38	DECAL - CAUTION/WARNING/DANGER (SEE 71-2000)	N/A	1
39	PETCOCK	23-0312	2
40	DECAL - TANK DRAIN (SEE 71-2000)	N/A	1
-	DECAL SET - AIR COMPRESSOR	71-2000	1

*MUST ORDER IN ONE FOOT LENGTHSV

COMPRESSOR/MOTOR ASSEMBLY (3-0395)

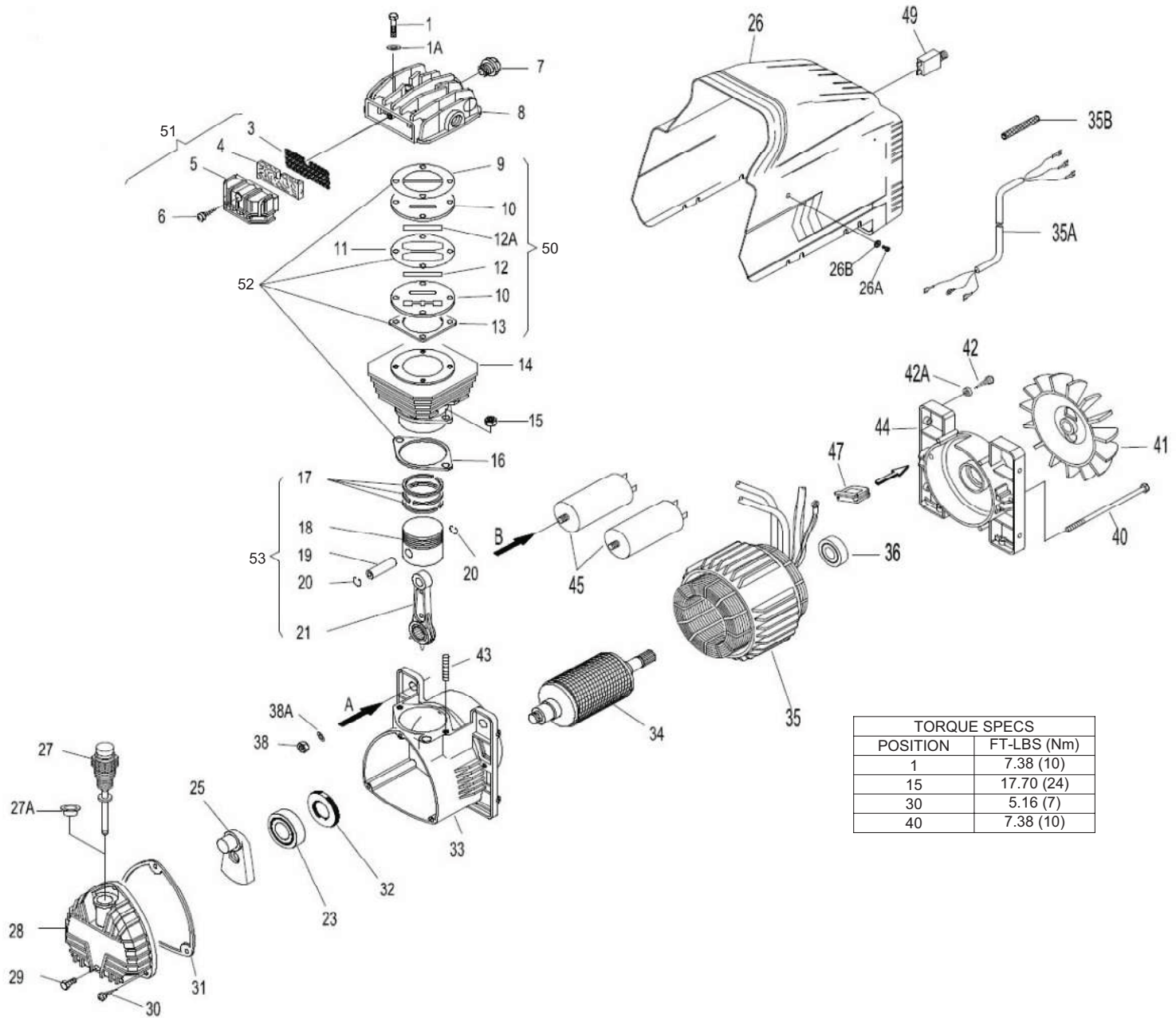

3-0395 123013 JDK

COMPRESSOR ASSEMBLY

ITEM	DESCRIPTION	PART #	QTY	ITEM	DESCRIPTION	PART #	QTY
1	SCREW	27-5027	4	27A	PLUG	N/A	1
1A	WASHER	28-0002	4	28	CRANKCASE COVER	46-1540	1
3	FILTER PLATE (SEE KIT 70-0633)	SEE KIT	1	29	OIL DRAIN CAP	39-0365	1
4	FILTERING ELEMENT (SEE KIT 70-0633)	19-0272	1	30	SCREW	27-8196	3
5	FILTER HOUSING (SEE KIT 70-0633)	SEE KIT	1	31	CRANKCASE COVER GASKET	26-0391	1
6	SCREW (SEE KIT 70-0633)	27-8901	1	32	OIL SEAL	26-0393	1
7	START VALVE	46-1534	1	33	CRANKCASE	46-1542	1
8	PUMP HEAD	46-1535	1	34	CRANKSHAFT ASSY.	52-0102	1
9	GASKET (SEE KIT 70-0630)	SEE KIT	1	35	STATOR WINDINGS	52-0105	1
10	VALVE PLATE (SEE KIT 70-0631)	SEE KIT	2	35A	ELECTRIC CABLE	52-0106	1
11	GASKET (SEE KIT 70-0630)	SEE KIT	1	35B	PLASTIC SLEEVE	N/A	1
12	VALVE (SEE KIT 70-0631)	SEE KIT	1	36	BALL BEARING	48-0098	1
12A	VALVE (SEE KIT 70-0631)	SEE KIT	1	38	NUT	30-0058	2
13	GASKET (SEE KIT 70-0630)	SEE KIT	1	38A	WASHER	28-0003	2
14	CYLINDER	46-1536	1	40	TENSION ROD	52-0103	2
15	NUT	30-0058	2	41	FAN	52-0104	1
16	GASKET (SEE KIT 70-0630)	SEE KIT	1	42	SCREW	N/A	1
17	PISTON RINGS KIT (SEE KIT 70-0632)	SEE KIT	1	42A	WASHER GROUND CONNECTION	28-1011	1
18	PISTON (SEE KIT 70-0632)	SEE KIT	1	43	STUD BOLT	46-1546	2
19	PISTON PIN (SEE KIT 70-0632)	SEE KIT	1	44	REAR COVER	52-0107	1
20	RETAINING RING (SEE KIT 70-0632)	SEE KIT	2	45	CAPACITOR	32-1140	2
21	CONNECTING ROD (SEE KIT 70-0632)	SEE KIT	1	47	RUBBER SEAL	52-0108	1
23	BALL BEARING	48-0097	1	49	THERMAL PROTECTION	32-1139	1
25	COUNTER WEIGHT	46-1537	1	50	KIT - VALVE PLATES - (INC. 10, 12A, 12)	70-0631	1
26	PLASTIC SHROUD	46-1538	1	51	KIT - INTAKE FILTER - (INC. 3-6)	70-0633	1
26A	SCREW	27-8189	2	52	KIT - GASKETS - (INC. 9, 11, 13, 16)	70-0630	1
26B	WASHER	28-0067	2	53	KIT - PISTON/CONNECTING ROD - (INC. 17-21)	70-0632	1
27	OIL DIPSTICK	46-1539	1				

Manufactured by Mi-T-M
8650 Enterprise Drive, Peosta IA 52068
563-556-7484/ Fax 563-556-1235