

## PARTS LIST FOR ***HDB/HDD SERIES***

### ENGINE OIL GRADE:

KOLHER/HONDA:

VANGUARD:

SAE10W-30

Above 40°F = SAE30

Below 40°F = SAE10W-30

### PUMP OIL GRADE:

### PUMP OIL CAPACITY:

SAE 20 or 30 Non-Detergent

SEE INDIVIDUAL

MACHINE SPECIFICATIONS

### FUEL NOZZLE:

HDB-3005:

HDD-3504/3804:

2.25 80° B Delavan

2.00 80° B Delavan

### BTU INPUT:

HDB-3005:

386,400

HDD-3504/3804:

343,000

### PRESSURE NOZZLE SIZE:

HDB-3005:

5.5

HDD-3804:

4.0

HDD-3504:

3.5

This Parts Listing has been compiled for your benefit. You can be assured your hot water pressure washer was constructed and designed with quality and performance in mind. Each component has been rigorously tested to insure the highest level of quality.

The contents of this Parts Listing are based on the latest product information available at the time of publication. The manufacturer reserves the right to make changes in price, color, materials, equipment, specifications or models at any time without notice.

### **WARNING**

THIS IS A PROFESSIONAL HIGH PRESSURE, HOT WATER PRESSURE WASHER. CAUTION SHOULD BE OBSERVED WHEN USING OR REPAIRING THIS UNIT! READ AND FOLLOW THE SAFETY WARNINGS LISTED BELOW BEFORE ATTEMPTING ANY REPAIRS ON THIS PRESSURE WASHER!

### **SAFETY WARNINGS**

1. NEVER alter or modify the equipment. Be sure any accessory items and system components being used will withstand the pressure developed. Use only genuine manufacturer parts for repair of your pressure washer. Failure to do so can cause hazardous operating conditions and will VOID warranty.
2. NEVER make adjustments on machinery while the unit is connected to the engine without first removing the ignition cable from the spark plug. Turning over the machinery by hand during adjustment or cleaning might start the engine and machinery with it, causing serious injury to the operator.
3. Know how to stop and bleed pressures quickly. Be thoroughly familiar with controls.
4. Before servicing the unit, turn unit off, relieve the water pressure and allow the unit to cool down. Do not make repairs while the unit is running. Service in a clean, dry, flat area. Block the wheels to prevent the unit from moving. Be especially careful to properly dispose of any flammable materials.
5. After operating the machine, DO NOT leave the pressurized unit unattended. Shut off the unit and release trapped pressure before leaving.

## Table of Contents

SPECIFICATIONS FOR HDB-3504-0H6A.....	5
SPECIFICATIONS FOR HDD-3504-0H6A.....	6
SPECIFICATIONS FOR HDD-3804-0V6A.....	7
FLOW CHART FOR HDB-3005.....	8
GENERAL THEORY OF OPERATION FOR HDB-3005 .....	9
FLOW CHART FOR HDD-3804.....	10
GENERAL THEORY OF OPERATION FOR HDD-3804 .....	11
FLOW CHART FOR HDD-3504.....	12
GENERAL THEORY OF OPERATION FOR HDD-3504 .....	13
SAFETY DECAL PLACEMENT HDB .....	14
SAFETY DECAL PLACEMENT HDD-3804-0V6A.....	16
SAFETY DECAL PLACEMENT HDD-3504-0H6A .....	17
HDB UNIT ASSEMBLY .....	18
HDD 3804 UNIT ASSEMBLY .....	20
HDD 3504 UNIT ASSEMBLY .....	22
HDB ISOLATION PLATE.....	24
HDD 3804 ISOLATION PLATE.....	26
HDD 3504 ISOLATION PLATE.....	28
HDB PUMP PLUMBING .....	30
HDD PUMP PLUMBING .....	32
ENGINE ASSEMBLY (850-0392).....	34
ENGINE ASSEMBLY (850-0332).....	36
PUMP ASSEMBLY (3-0202) (AFTER SERIAL #15045000).....	38
PUMP ASSEMBLY (3-0208) .....	40
PUMP ASSEMBLY (3-0310) .....	42
HDB GAS TANK ASSEMBLY .....	44
BURNER FUEL TANK.....	45
CONTROL PANEL ASSEMBLY .....	46
HDD HEAT EXCHANGER ASSEMBLY.....	48
HDB HEAT EXCHANGER ASSEMBLY.....	50
BURNER ASSEMBLY (4-0021) .....	52
UNLOADER ASSEMBLY (850-0304) .....	54
UNLOADER ASSEMBLY (850-0252) .....	56

## Table of Contents

PRESSURE SWITCH (22-0243) .....	58
GUN/WAND/HOSE ASSEMBLY .....	60
GUN ASSEMBLY (16-0392) .....	62
DUAL LANCE ASSEMBLY (16-0417) .....	64
WIRING SCHEMATIC .....	66
WIRING DIAGRAM .....	67
3-WAY BALL VALVE OPTION (HX-0130) .....	68
TRAPPING UNLOADER OPTION (HX-0225) .....	70
CONTROL PANEL (HX-0156/0220/0221/0222/0224) .....	71
FLOAT TANK OPTION (HX-0220/0221).....	72
FLOAT TANK ASSEMBLY.....	74
STEAM OPTION PLUMBING (HX-0224) .....	75

## SPECIFICATIONS FOR HDB-3504-0H6A

MODEL NUMBER	HDB-3005-0V6G	HDB-3005-0K6G
Operating Pressure (PSI/Bar):	3000 / 206.8 (+/-5%)	
Water Volume (GPM/lpm):	4.8 / 18.2 (+/-5%)	
Outlet Water Temperature (F/C)	130°F / 54°C (+/- 10°F) rise above inlet ambient (210°F / 99°C maximum)	
High Pressure Nozzle	5.5	
Engine:	Brigs and Stratton	Kohler
Model	Vanguard 16	CH620
Engine Type	4 Stroke, Overhead Valve, Twin Cylinder	
Oil Type	above 40°F = SAE30 / Below 40°F = SAE 10W-30	SAE10-30W
Oil Capacity (oz. / liter)	56 / 1.66	64 / 1.89
Low Oil Protection	Oil Guard™	Oil Sentry™
Fuel Type	Refer to Engine Owner's Manual	
Fuel Capacity (Gal. / liter)	10 / 37.8	
Starting	12 Volt Electric	
Battery	BCI Group 24DC, RV / Marine Dual Purpose Deep Cycle / Cranking Battery	
Maximum No Load RPM	3600 (+/- 100)	
High Pressure Pump:	Belt Driven, Oil Bath, Triplex Piston	
Oil Type	SAE20 or 30 Non-Detergent	
Oil Capacity (oz. / liter)	41 / 1.2	
Plungers	Ceramic	
Manifold	Forged Brass	
Valves	Stainless Steel	
Unloader	Flow Sensitive - Pre-set at the factory	
Heat Dump Valve	Relieves heated water during unloader bypass stage	
Water System:		
Inlet Water Strainer	Removable thimble for inspection and cleaning of stainless steel screen	
Heat Dump Valve	Protects pump against damaging heat in recirculated and inlet water	
Burner Fuel System		
Fuel Type	No 1 or No 2 Fuel Oil, Diesel or Kerosene	
Fuel Capacity (Gal. / liter)	10 / 37.8	
Fuel Filter/ Water Separator	Spin on (10 micron) filter / E-Z water drain	
Fuel Pump	Two Line, Single Stage	
Fuel Pressure (PSI / BAR)	150 / 10.4	
Fuel Nozzle	2.25 80° B Delavan	
Fuel Consumption (GPH / LPH)	2.76 / 10.45 Cont. Burning	
Burner Electrical System		
Voltage	12	
Amps	16.0	
Heat Exchanger	Horizontal, Side Fired, Pancake Coil	
BTU Input	386,400	
Efficiency	75% with #2 Fuel Oil / Diesel	
Smoke Density	0-3 Per ASTM D2156	
Safety System		
Pressure Switch	Shuts off burner fuel supply upon trigger release	
Fuel Solenoid	12 Volt, controls fuel supply to burner	
Safety Relief	Relieves excess system pressure	
Unit Net Weight (Lbs/kg)	601 / 273	617 / 280
Unit Shipping Weight (Lbs/kg)	720 / 327	736 / 334
Unit Net Dimensions (In/cm)	53.5L x 28.75W x 42H / 135.9L x 70W x 106.7H	
Unit Shipping Dimensions (In/cm)	57.5L x 35.5W x 59.5H / 146.1L x 90.2W x 151.1H	

## SPECIFICATIONS FOR HDD-3504-0H6A

MODEL NUMBER	HDD-3504-0H6A
Operating Pressure (PSI/Bar):	3500 / 241.3 (+/-5%)
Water Volume (GPM/lpm):	3.3 / 12.5 (+/-5%)
Outlet Water Temperature (F/C)	130°F / 54°C (+/- 10°F) rise above inlet ambient (210°F / 99°C maximum)
High Pressure Nozzle	3.5
Engine:	Honda
Model	GX390
Engine Type	4 Stroke, Overhead Valve, Single Cylinder
Oil Type	SAE 10W-30
Oil Capacity (oz. / liter)	37 / 1.1
Low Oil Protection	Oil Alert™
Fuel Type	Unleaded Gasoline 86 Octane Minimum
Fuel Capacity (Gal. / liter)	1.7 / 6.5
Starting	12 Volt Electric
Battery	BCI Group 24DC, RV / Marine Dual Purpose Deep Cycle / Cranking Battery
Maximum No Load RPM	3600 (+/- 100)
High Pressure Pump:	Direct Driven, Oil Bath, Triplex Piston
Oil Type	SAE20 or 30 Non-Detergent
Oil Capacity (oz. / liter)	15.0 / .44
Plungers	Ceramic
Manifold	Forged Brass
Valves	Stainless Steel
Unloader	Pressure Trapping - Pre-set at the factory
Heat Dump Valve	Relieves heated water during unloader bypass stage
Water System:	
Inlet Water Strainer	Removable thimble for inspection and cleaning of stainless steel screen
Heat Dump Valve	Protects pump against damaging heat in recirculated and inlet water
Burner Fuel System:	
Fuel Type	No 1 or No 2 Fuel Oil, Diesel or Kerosene
Fuel Capacity (Gal. / liter)	10 / 37.8
Fuel Filter/ Water Separator	Spin on (10 micron) filter / E-Z water drain
Fuel Pump	Two Line, Single Stage
Fuel Pressure (PSI / BAR)	150 / 10.4
Fuel Nozzle	2.00 80° B Delavan
Fuel Consumption (GPH / LPH)	2.45 / 9.27 Cont. Burning
Burner Electrical System:	
Voltage	12
Amps	16.0
Heat Exchanger:	Horizontal, Side Fired, Pancake Coil
BTU Input	343,000
Efficiency	75% with #2 Fuel Oil / Diesel
Smoke Density	0-3 Per ASTM D2156
Safety System:	
Pressure Switch	Shuts off burner fuel supply upon trigger release
Fuel Solenoid	12 Volt, controls fuel supply to burner
Safety Relief	Relieves excess system pressure
Unit Net Weight (Lbs/kg)	533 / 242
Unit Shipping Weight (Lbs/kg)	652 / 296
Unit Net Dimensions (In/cm)	53.5L x 28.75W x 42H / 135.9L x 70W x 106.7H
Unit Shipping Dimensions (In/cm)	57.5L x 35.5W x 59.5H / 146.1L x 90.2W x 151.1H

## SPECIFICATIONS FOR HDD-3804-0V6A

MODEL NUMBER	HDD-3804-0V6A
Operating Pressure (PSI/Bar):	3800 / 262.0 (+/-5%)
Water Volume (GPM/lpm):	3.9 / 14.8 (+/-5%)
Outlet Water Temperature (F/C)	130°F / 54°C (+/- 10°F) rise above inlet ambient (210°F / 99°C maximum)
High Pressure Nozzle	4.0
Engine:	Briggs and Stratton
Model	Vanguard 16
Engine Type	4 Stroke, Overhead Valve, Twin Cylinder
Oil Type	above 40°F = SAE30 / Below 40°F = SAE 10W-30
Oil Capacity (oz. / liter)	56 / 1.66
Low Oil Protection	Oil Guard™
Fuel Type	Refer to Engine Owner's Manual
Fuel Capacity (Gal. / liter)	10 / 37.8
Starting	12 Volt Electric
Battery	BCI Group 24DC, RV / Marine Dual Purpose Deep Cycle / Cranking Battery
Maximum No Load RPM	3600 (+/- 100)
High Pressure Pump:	Direct Driven, Oil Bath, Triplex Piston
Oil Type	SAE20 or 30 Non-Detergent
Oil Capacity (oz. / liter)	15.0 / .44
Plungers	Ceramic
Manifold	Forged Brass
Valves	Stainless Steel
Unloader	Pressure Trapping - Pre-set at the factory
Heat Dump Valve	Relieves heated water during unloader bypass stage
Water System:	
Inlet Water Strainer	removable thimble for inspection and cleaning of stainless steel screen
Heat Dump Valve	Protects pump against damaging heat in recirculated and inlet water
Burner Fuel System:	
Fuel Type	No 1 or No 2 Fuel Oil, Diesel or Kerosene
Fuel Capacity (Gal. / liter)	10 / 37.8
Fuel Filter/ Water Separator	Spin on (10 micron) filter / E-Z water drain
Fuel Pump	Two Line, Single Stage
Fuel Pressure (PSI / BAR)	150 / 10.4
Fuel Nozzle	2.00 80° B Delavan
Fuel Consumption (GPH / LPH)	2.45 / 9.27 Cont. Burning
Burner Electrical System:	
Voltage	12
Amps	16.0
Heat Exchanger:	Horizontal, Side Fired, Pancake Coil
BTU Input	343,000
Efficiency	75% with #2 Fuel Oil / Diesel
Smoke Density	0-3 Per ASTM D2156
Safety System:	
Pressure Switch	Shuts off burner fuel supply upon trigger release
Fuel Solenoid	12 Volt, controls fuel supply to burner
Safety Relief	Relieves excess system pressure
Unit Net Weight (Lbs/kg)	558 / 254
Unit Shipping Weight (Lbs/kg)	677 / 307
Unit Net Dimensions (In/cm)	53.5L x 28.75W x 42H / 135.9L x 70W x 106.7H
Unit Shipping Dimensions (In/cm)	57.5L x 35.5W x 59.5H / 146.1L x 90.2W x 151.1H





## GENERAL THEORY OF OPERATION FOR HDB-3005

**WATER FLOW:** Connect a pressurized water source to the INLET GARDEN HOSE CONNECTION (4) and turn on the water supply.

The water is fed through a filter on the INLET GARDEN HOSE CONNECTION (4) and into the TRIPLEX HIGH PRESSURE PUMP (5) which has an UNLOADER (1) that bypasses the water when the trigger gun is closed. To protect the pump from heated water during this bypass stage, a HEAT DUMP VALVE (2) will open at 140°F/60°C allowing the heated water to escape. The Heat Dump Valve automatically resets when the water cools. The BURNER CONTROL PRESSURE SWITCH (3) controls the fuel supply to the burner.

From there, the water flows through HEAT EXCHANGER INLET (12) where it is heated when the burner is on. As the water exits the HEAT EXCHANGER OUTLET (13), it enters a safety system which protects the operator from danger. The system also contains a ADJUSTABLE THERMOSTAT (14) which senses the water temperature and shuts off the fuel supply to the burner if the water gets too hot. If the unloader fails to bypass water or the burner remains on when the trigger gun is closed, the SAFETY RELIEF (15) will relieve and allow water to exit safely.

The heated water then flows through the HIGH PRESSURE HOSE (16) and to the TRIGGER GUN ASSEMBLY (17) which allows the operator to control the water spray. When the trigger gun is open, the water flows through the ADJUSTABLE PRESSURE DUAL LANCE (18) and exits the NOZZLE (19).

**FUEL FLOW:** The Fuel Pump draws fuel from the FUEL TANK (7) through a replaceable FUEL FILTER/WATER SEPARATOR (8) and into the FUEL PUMP (9). Fuel exits the fuel pump, into a FUEL SOLENOID VALVE (10) which controls fuel flow to the FUEL NOZZLE (11) where it ignites and burns in the heat exchanger. The engine is operated by fuel drawn from the GAS TANK (6).

# FLOW CHART FOR HDD-3804

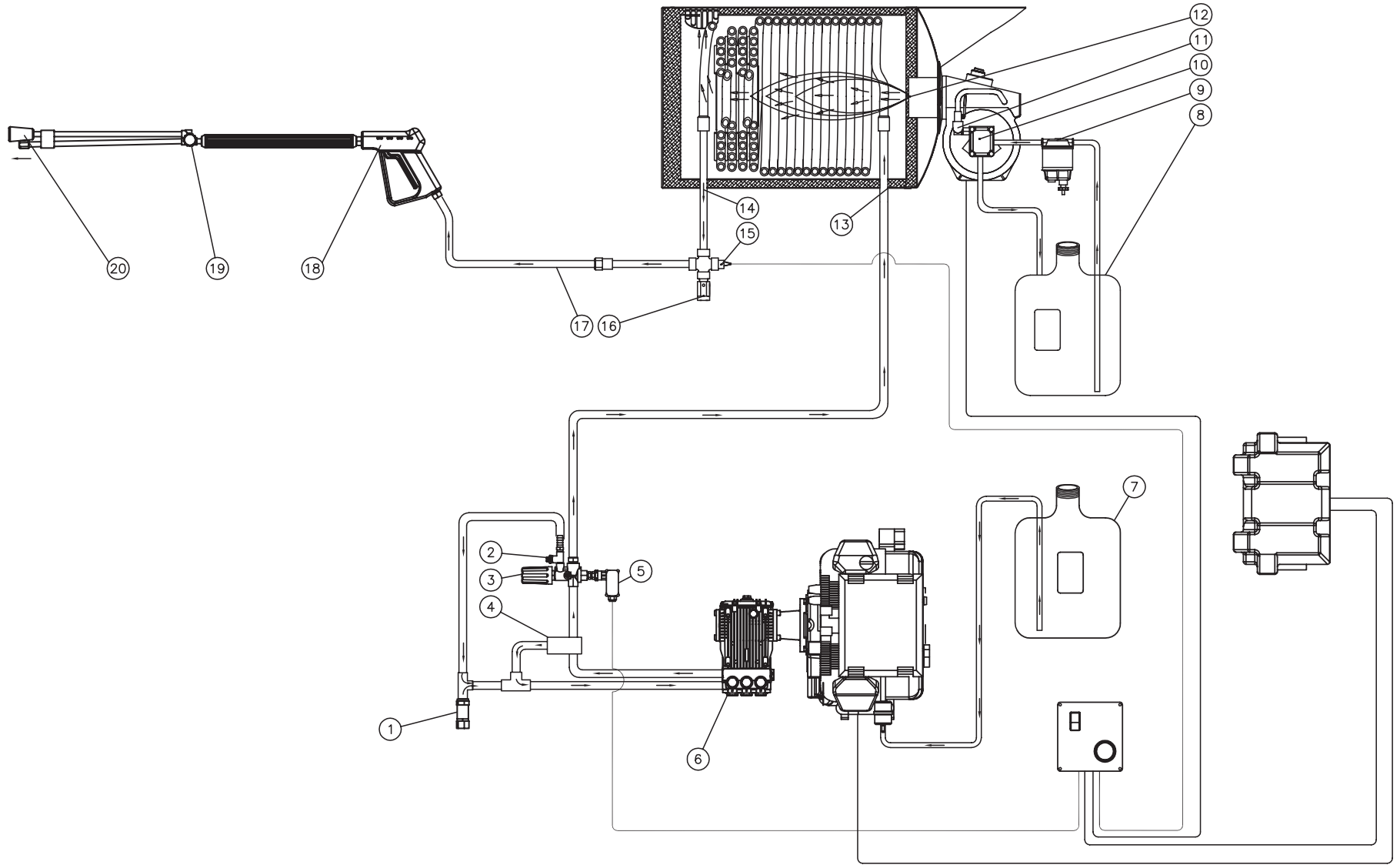

HDD-3804 FLOW DIAGRAM-011410-CH

## GENERAL THEORY OF OPERATION FOR HDD-3804

**WATER FLOW:** Connect a pressurized water source to the INLET GARDEN HOSE CONNECTION (1) and turn on the water supply.

The water is fed through a filter on the INLET GARDEN HOSE CONNECTION (1) and into the TRIPLEX HIGH PRESSURE PUMP (6) which has an UNLOADER (3) that bypasses the water when the trigger gun is closed. To protect the pump from heated water during this bypass stage, a HEAT DUMP VALVE (2) will open at 140°F/60°C allowing the heated water to escape. The Heat Dump Valve automatically resets when the water cools. The EASY START VALVE (4) will allow the engine to start without a load. The water recirculates until pressure builds up and forces the seat closed. The BURNER CONTROL PRESSURE SWITCH (5) controls the fuel supply to the burner.

From there, the water flows through HEAT EXCHANGER INLET (13) where it is heated when the burner is on. As the water exits the HEAT EXCHANGER OUTLET (14), it enters a safety system which protects the operator from danger. The system also contains an ADJUSTABLE THERMOSTAT (15) which senses the water temperature and shuts off the fuel supply to the burner if the water gets too hot. If the unloader fails to bypass water or the burner remains on when the trigger gun is closed, the SAFETY RELIEF (16) will relieve and allow water to exit safely.

The heated water then flows through the HIGH PRESSURE HOSE (17) and to the TRIGGER GUN ASSEMBLY (18) which allows the operator to control the water spray. When the trigger gun is open, the water flows through the ADJUSTABLE PRESSURE DUAL LANCE (19) and exits the NOZZLE (20).

**FUEL FLOW:** The Fuel Pump draws fuel from the FUEL TANK (8) through a replaceable FUEL FILTER/WATER SEPARATOR (9) and into the FUEL PUMP (10). Fuel exits the fuel pump, into a FUEL SOLENOID VALVE (11) which controls fuel flow to the FUEL NOZZLE (12) where it ignites and burns in the heat exchanger. The engine is operated by fuel drawn from the GAS TANK (7).

# FLOW CHART FOR HDD-3504

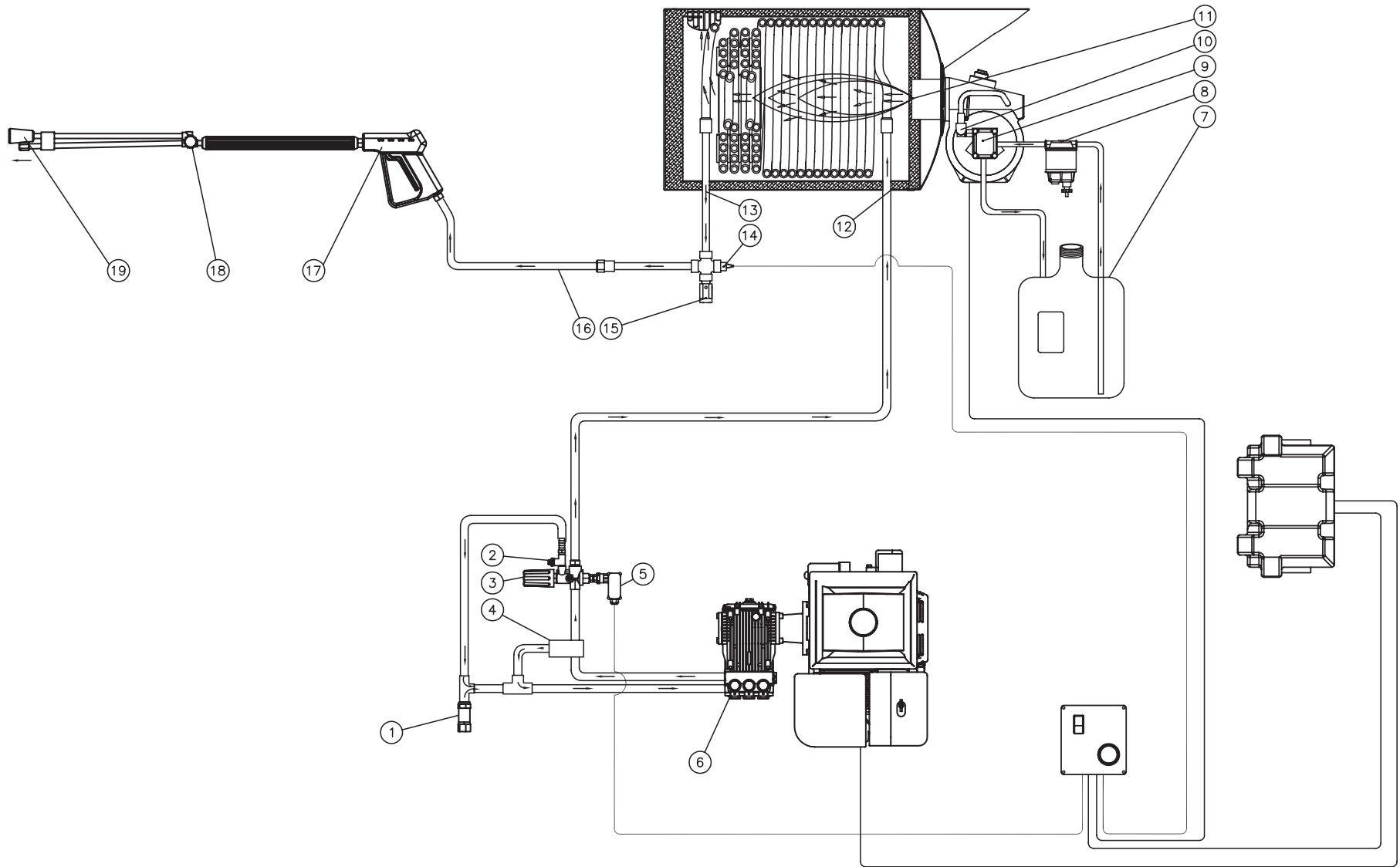

HDD-3504 FLOW DIAGRAM-011410-CH

## GENERAL THEORY OF OPERATION FOR HDD-3504

**WATER FLOW:** Connect a pressurized water source to the INLET GARDEN HOSE CONNECTION (1) and turn on the water supply.

The water is fed through a filter on the INLET GARDEN HOSE CONNECTION (1) and into A TRIPLEX HIGH PRESSURE PUMP (6) which has an UNLOADER (3) that bypasses the water when the trigger gun is closed. To protect the pump from heated water during this bypass stage, a HEAT DUMP VALVE (2) will open at 140°F/60°C allowing the heated water to escape. The Heat Dump Valve automatically resets when the water cools. The EASY START VALVE (4) will allow the engine to start without a load. The water recirculates until pressure builds up and forces the seat closed. The BURNER CONTROL PRESSURE SWITCH (5) controls the fuel supply to the burner.

From there, the water flows through HEAT EXCHANGER INLET (12) where it is heated when the burner is on. As the water exits the HEAT EXCHANGER OUTLET (13), it enters a safety system which protects the operator from danger. The system also contains an ADJUSTABLE THERMOSTAT (14) which senses the water temperature and shuts off the fuel supply to the burner if the water gets too hot. If the unloader fails to bypass water or the burner remains on when the trigger gun is closed, the SAFETY RELIEF (15) will relieve and allow water to exit safely.

The heated water then flows through the HIGH PRESSURE HOSE (16) and to the TRIGGER GUN ASSEMBLY (17) which allows the operator to control the water spray. When the trigger gun is open, the water flow through the ADJUSTABLE PRESSURE DUAL LANCE (18) and exits the NOZZLE (19).

**FUEL FLOW:** The Fuel Pump draws fuel from the FUEL TANK (7) through a replaceable FUEL FILTER/WATER SEPARATOR (8) and into the FUEL PUMP (9). Fuel exits the fuel pump, into a FUEL SOLENOID VALVE (10) which controls fuel flow to the FUEL NOZZLE (11) where it ignites and burns in the heat exchanger. The engine is operated by fuel drawn from the gas tank on the engine.

# SAFETY DECAL PLACEMENT HDB

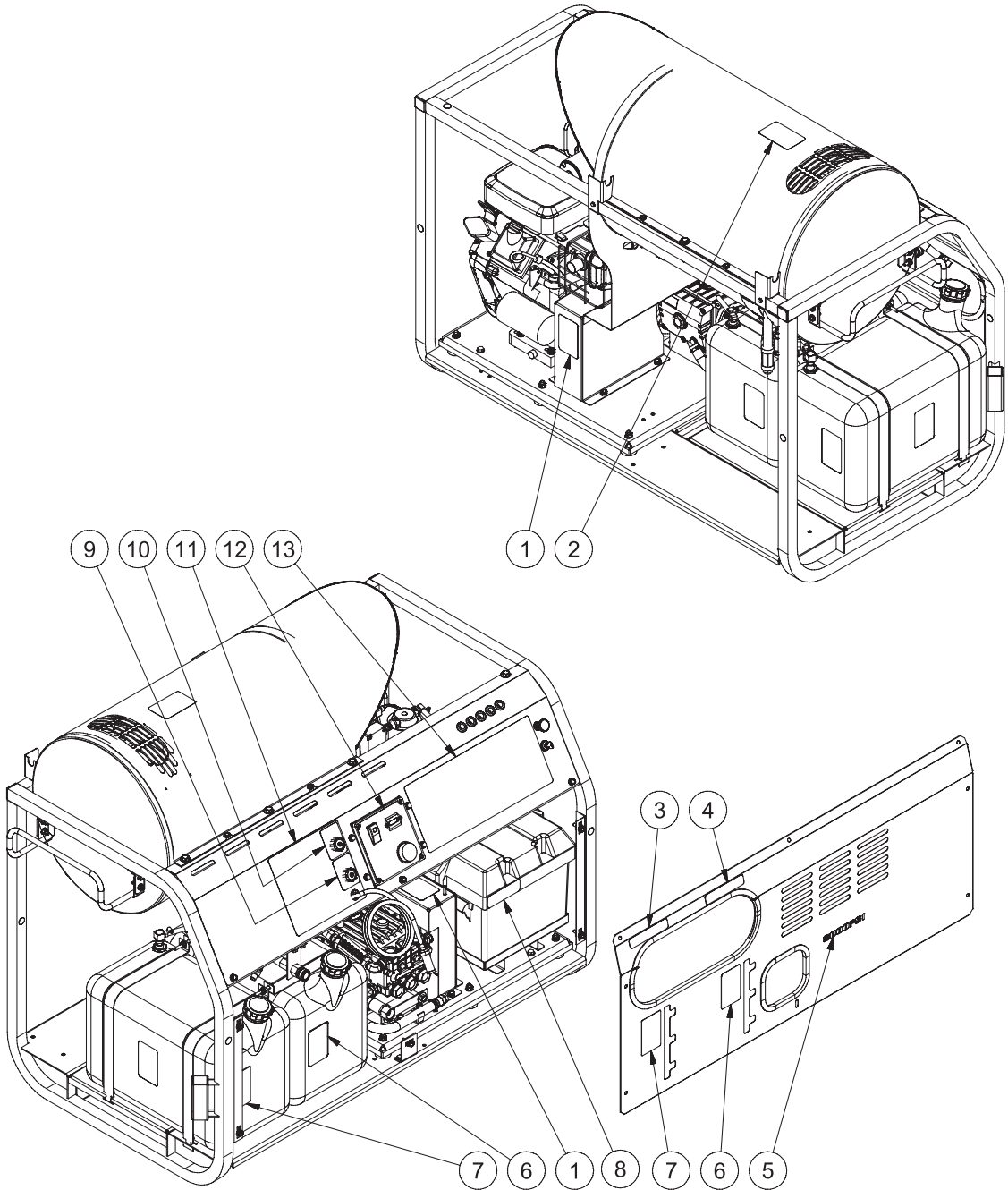

HDB DECAL PLACEMENT 101310-CH

HDB DECAL PLACEMENT 011310 CH			
HDB DECAL PLACEMENT			
ITEM	DESCRIPTION	Mi-T-M #	QTY
1	DECAL - WARNING; RISK OF INJURY	N/A	2
2	DECAL - WARNING HOT SURFACES	N/A	1
3	DECAL - GASOLINE ONLY	N/A	1
4	DECAL - DIESEL ONLY	N/A	1
5	DECAL- DIE CUT 3000 PSI	34-2214	1
6	DECAL- CAUTION RISK OF FIRE	N/A	2
7	DECAL- CAUTION:GASOLINE ONLYEFS	N/A	2
8	DECAL - CAUTION RISK OF INJURY (E/S)	N/A	1
9	DECAL - DETERGENT VALVE (HX-0220, HX-0221)	N/A	1
10	DECAL - STEAM VALVE (HX-0224)	N/A	1
11	DECAL - OPERATION	N/A	1
12	DECAL - CONTROLS	N/A	1
-	DECAL - CONTROLS W/ HOUR METER (HX-0156)	N/A	1
13	DECAL - WARNINGS	N/A	1
-	DECAL SET - HDS (INC. 1-4, 6-13)	34-9000	1

## SAFETY DECAL PLACEMENT HDD-3804-0V6A

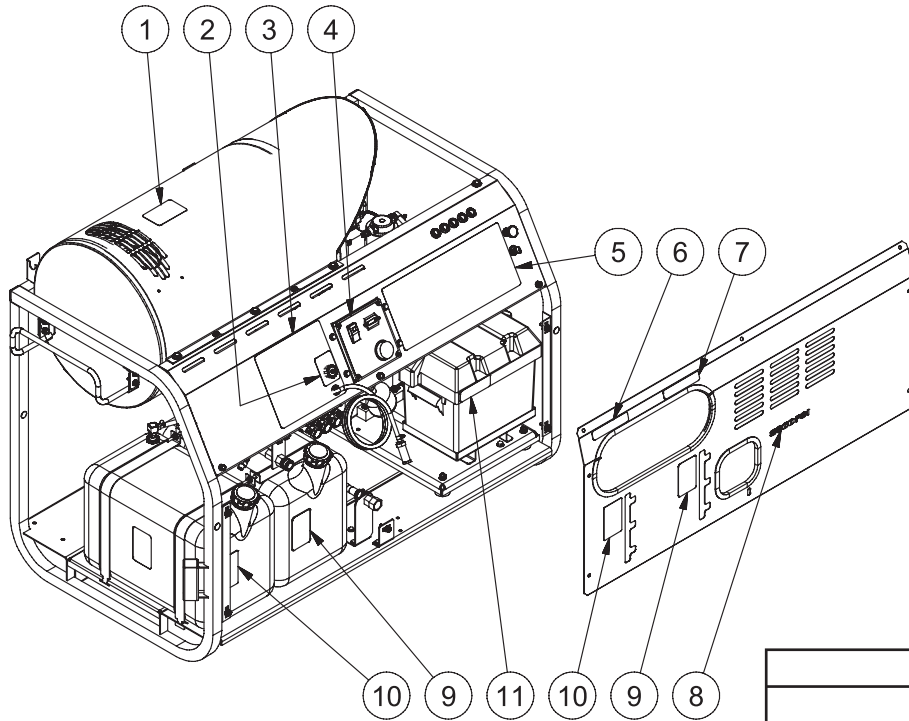

HDD DECAL PLACEMENT 3804 011310-CH			
HDD 3804 DECAL PLACEMENT			
ITEM	DESCRIPTION	Mi-T-M #	QTY
1	DECAL - WARNING HOT SURFACES	N/A	1
2	DECAL - DETERGENT VALVE (HX-0220, HX-0221)	N/A	1
3	DECAL - OPERATION	N/A	1
4	DECAL - CONTROLS	N/A	1
-	DECAL - CONTROLS W/HOUR METER (HX-0156)	N/A	1
5	DECAL - WARNINGS	N/A	1
6	DECAL - GASOLINE ONLY	N/A	1
7	DECAL - DIESEL ONLY	N/A	1
8	DECAL - DIE CUT 3800 PSI	34-2444	1
9	DECAL- CAUTION RISK OF FIRE	N/A	2
10	DECAL- CAUTION:GASOLINE ONLYEFS	N/A	2
11	DECAL - CAUTION RISK OF INJURY (E/S)	N/A	1
-	DECAL SET (INC 1-7, 9-11)	34-9000	1

HDD DECAL PLACEMENT 3804 101310-CH



## SAFETY DECAL PLACEMENT HDD-3504-0H6A

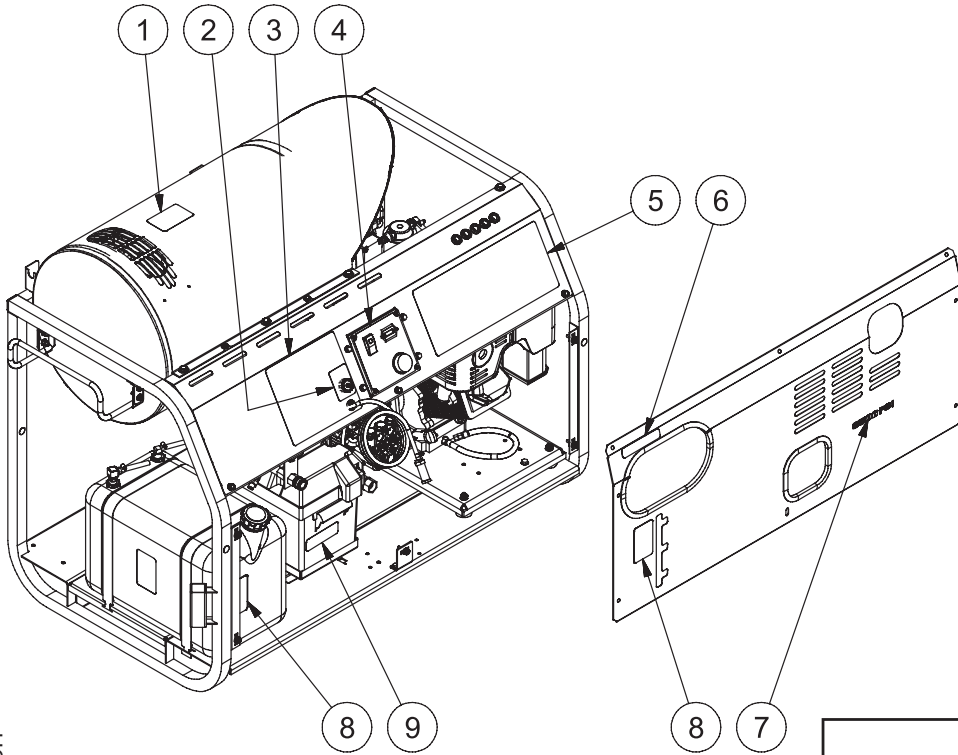

HDD DECAL PLACEMENT 3504 011310 CH			
HDD 3504 DECAL PLACEMENT			
ITEM	DESCRIPTION	Mi-T-M #	QTY
1	DECAL - WARNING HOT SURFACES	N/A	1
2	DECAL - DETERGENT VALVE (HX-0220, HX-0221)	N/A	1
3	DECAL - OPERATION	N/A	1
4	DECAL - CONTROLS	N/A	1
-	DECAL - CONTROLS W/HOUR METER (HX-0156)	N/A	1
5	DECAL - WARNINGS	N/A	1
6	DECAL - DIESEL ONLY	N/A	1
7	DECAL - DIE CUT 3500 PSI	34-2215	1
8	DECAL- CAUTION RISK OF FIRE	N/A	2
9	DECAL - CAUTION RISK OF INJURY (E/S)	N/A	1
-	DCAL SET (INC 1-6, 8-9)	34-9000	1

HDD DECAL PLACEMENT 3504 101310-CH

# HDB UNIT ASSEMBLY

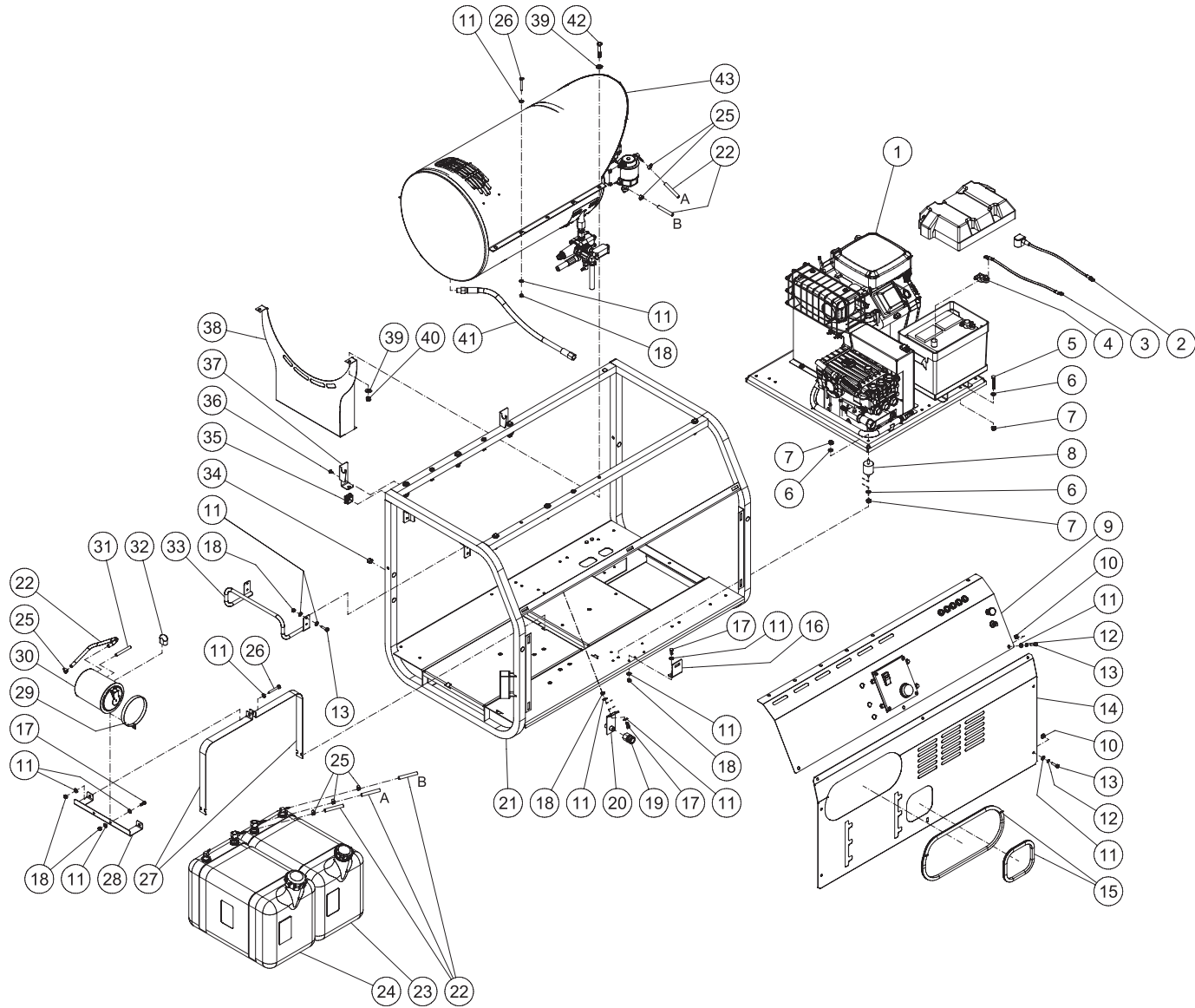

HDB UNIT ASSEMBLY-070512-CH

HDB UNIT ASSEMBLY 060512 CH			
UNIT ASSEMBLY			
ITEM	DESCRIPTION	Mi-T-M #	QTY
1	ISOLATION PLATE ASSEMBLY	N/A	1
2	CABLE	32-9114	1
3	CABLE	32-9113	1
4	BATTERY END	32-0066	2
5	BOLT	27-0071	2
6	WASHER	28-0003	18
7	LOCKNUT	30-0157	18
8	ISOLATOR	14-0110	8
9	CONTROL PANEL ASSEMBLY	N/A	1
10	CLIP NUT	30-6027	8
11	WASHER	28-0002	40
12	LOCKWASHER	29-0006	8
13	BOLT	27-0016	12
14	FRONT PANEL	21-0292	1
15	EDGING *(FIVE FEET REQUIRED)	33-0020	1
16	BRACKET	20-1182A18	1
17	BOLT	27-0015	6
18	LOCKNUT	30-0155	16
19	QC SOCKET	17-0004	1
20	WATER OUTLET BRACKET	20-1168A18	1
21	FRAME	5-0294A18	1
22	FUEL HOSE *(SIXTEEN FEET REQUIRED)	15-0008	1
23	BURNER FUEL TANK ASSEMBLY	N/A	1
24	GAS TANK ASSEMBLY (HDB-3005-0V6G_0K6G)	N/A	1
25	CLAMP WORM	42-0004	6
26	BOLT	27-0020	6
27	TANK STRAP	20-0585A18	4
28	CARB CANISTER MOUNT (GASOLINE MODELS ONLY)	20-1197A18	1
29	CARB CANISTER STRAP (GASOLINE MODELS ONLY)	20-1187A01	2
30	CARB CANISTER (GASOLINE MODELS ONLY)	62-0212	1
31	FUEL HOSE *(SIX FEET REQUIRED) (GASOLINE MODELS ONLY)	15-0261	1
32	BREATHER VENT COVER (GASOLINE MODELS ONLY)	62-0218	1
33	HOSE HANGER	20-1165A18	1
34	PLUG	39-0234	13
35	PLUG	39-0238	2
36	BOLT	27-3062	2
37	GUN/ WAND HOLDER	20-1166A18	2
38	HEAT SHIELD (HDB-3005-0V6G_0K6G)	20-1161A18	1
39	WASHER	28-0022	14
40	LOCKNUT	30-0159	7
41	HIGH PRESSURE HOSE	15-0202	1
42	BOLT	27-0122	7
43	HEAT EXCHANGER ASSEMBLY	N/A	1
*MUST ORDER IN ONE FOOT LENGTHS			

# HDD 3804 UNIT ASSEMBLY

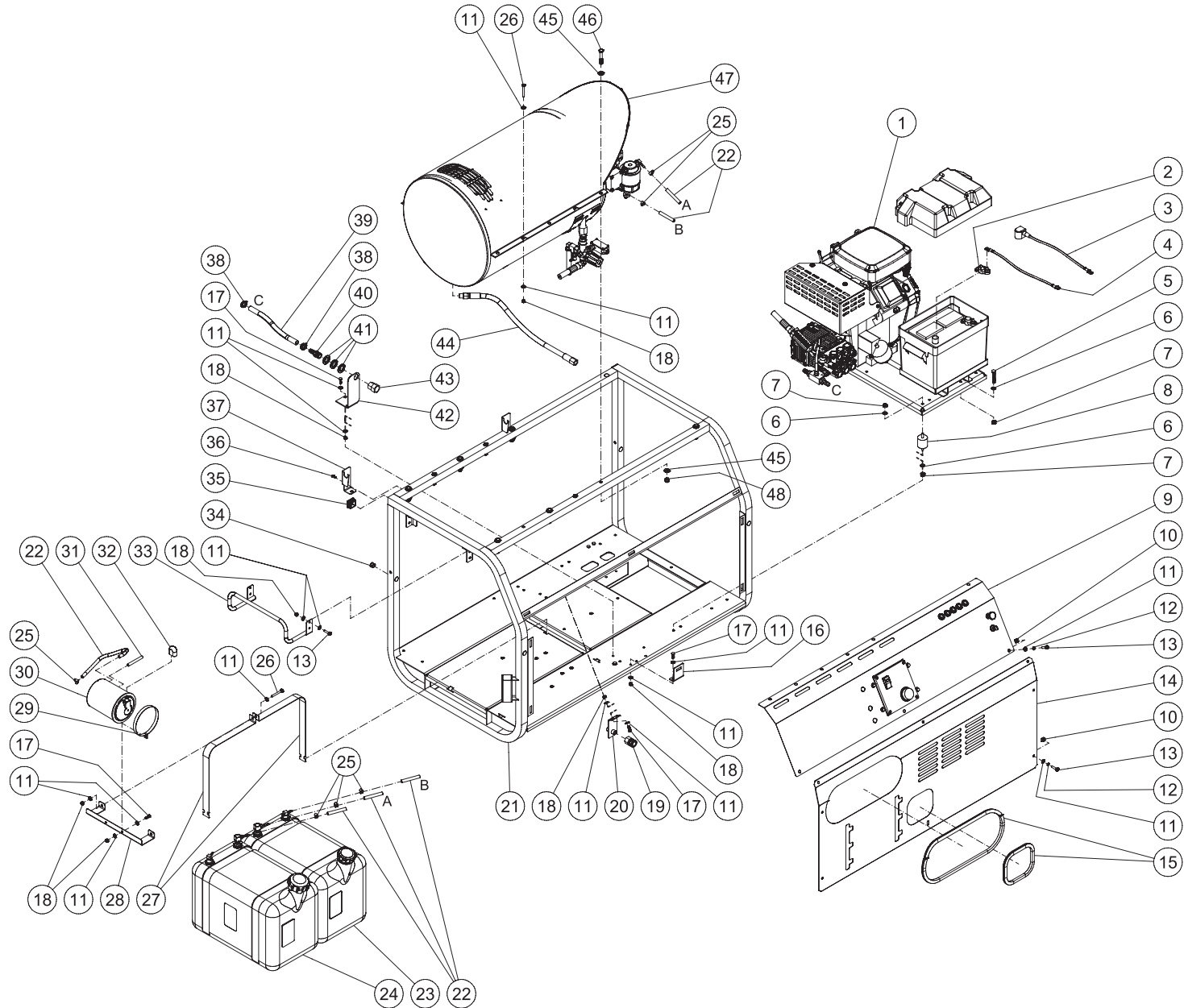

HDD 3804 UNIT ASSEMBLY-060512-CH

HDD-3804-0V6A UNIT ASSEMBLY			
UNIT ASSEMBLY			
ITEM	DESCRIPTION	Mi-T-M #	QTY
1	ISOLATION PLATE ASSEMBLY	N/A	1
2	BATTERY END	32-0066	2
3	CABLE	32-9114	1
4	CABLE	32-9113	1
5	BOLT	27-0071	2
6	WASHER	28-0003	10
7	LOCKNUT	30-0157	10
8	ISOLATOR	14-0110	4
9	CONTROL PANEL ASSEMBLY	N/A	1
10	CLIP NUT	30-6027	8
11	WASHER	28-0002	44
12	LOCKWASHER	29-0006	8
13	BOLT	27-0016	12
14	FRONT PANEL	21-0292	1
15	EDGING *(FIVE FEET REQUIRED)	33-0020	1
16	BRACKET	20-1182A18	1
17	BOLT	27-0015	8
18	LOCKNUT	30-0155	18
19	QC SOCKET	17-0004	1
20	WATER OUTLET BRACKET	20-1168A18	1
21	FRAME	5-0294A18	1
22	FUEL HOSE *(FOURTEEN FEET REQUIRED)	15-0008	1
23	BURNER FUEL TANK ASSEMBLY	N/A	1
24	GAS TANK ASSEMBLY	N/A	1
25	CLAMP WORM	42-0004	6
26	BOLT	27-0020	6
27	TANK STRAP	20-0585A18	4
28	CARB CANISTER MOUNT	20-1197A18	1
29	CARB CANISTER STRAP	20-1187A01	2
30	CARB CANISTER	62-0212	1
31	FUEL HOSE *(SIX FEET REQUIRED)	15-0261	1
32	BREATHER VENT COVER	62-0218	1
33	HOSE HANGER	20-1165A18	1
34	PLUG	39-0234	9
35	PLUG	39-0238	2
36	BOLT	27-3062	2
37	GUN/ WAND HOLDER	20-1166A18	2
38	HOSE CLAMP	42-0011	2
39	HOSE *(THREE FEET REQUIRED)	15-0007	1
40	BARB	23-0045	1
41	WASHER	28-0051	3
42	WATER INLET BRACKET	20-1181A18	1
43	SWIVEL	23-0001	1
44	HIGH PRESSURE HOSE	15-0202	1
45	WASHER	28-0022	14
46	BOLT	27-0122	7
47	HEAT EXCHANGER ASSEMBLY	N/A	1
48	LOCKNUT	30-0159	7

\*MUST ORDER IN ONE FOOT LENGTHS

# HDD 3504 UNIT ASSEMBLY

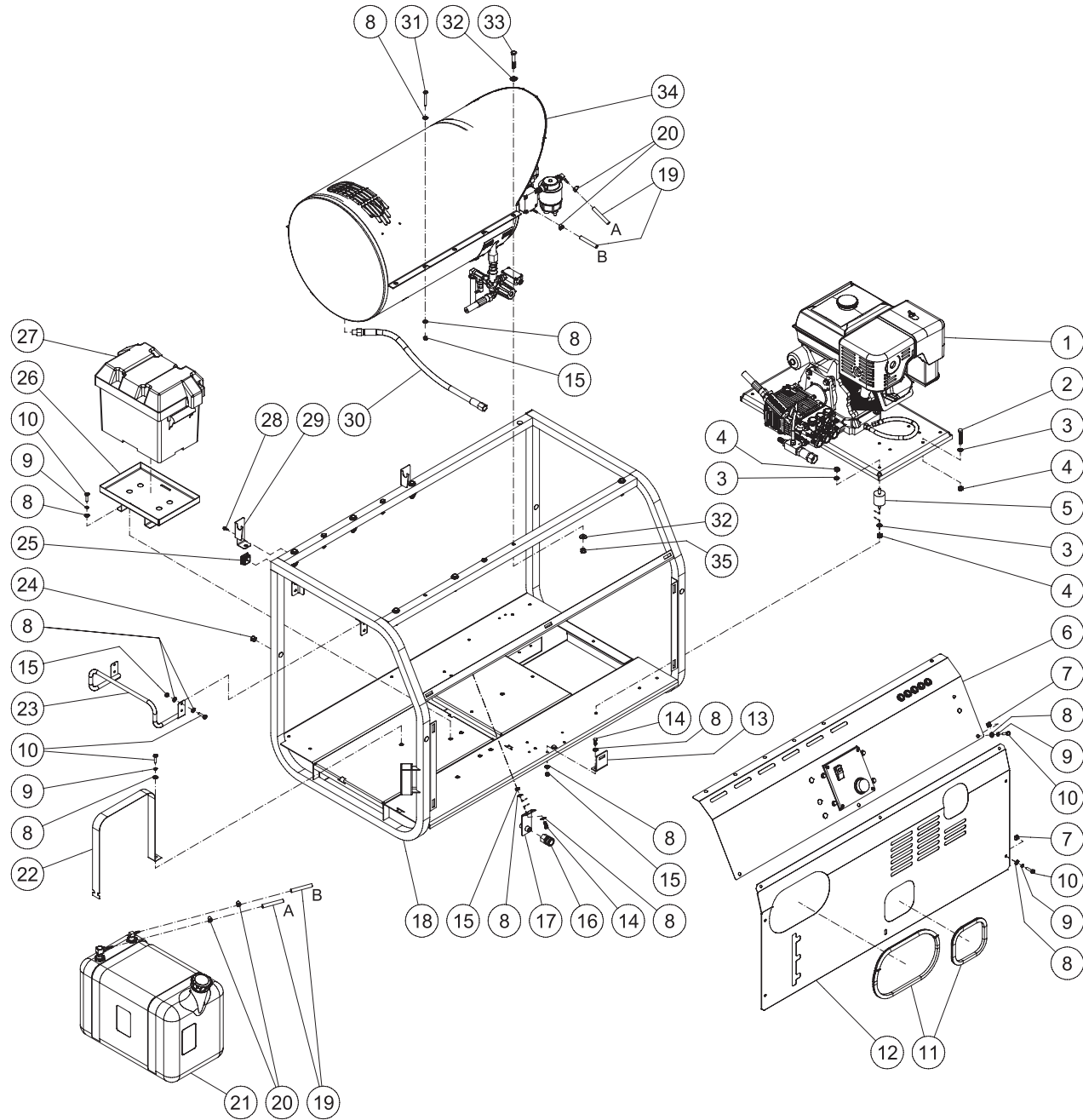

HDD 3504 UNIT ASSEMBLY-121809-CH

HDD-3504-0V6A UNIT ASSEMBLY 121809 CH			
HDD 3504 UNIT ASSEMBLY			
ITEM	DESCRIPTION	Mi-T-M #	QTY
1	ISOLATION PLATE ASSEMBLY	N/A	1
2	BOLT	27-0071	2
3	WASHER	28-0003	10
4	LOCKNUT	30-0157	10
5	ISOLATOR	14-0110	4
6	CONTROL PANEL ASSEMBLY	N/A	1
7	CLIP NUT	30-6027	8
8	WASHER	28-0002	38
9	LOCKWASHER	29-0006	14
10	BOLT	27-0016	18
11	EDGING *(THREE FEET REQUIRED)	33-0020	1
12	FRONT PANEL	21-0293	1
13	BRACKET	20-1182A18	1
14	BOLT	27-0015	4
15	LOCKNUT	30-0155	12
16	QC SOCKET	17-0004	1
17	WATER OUTLET BRACKET	20-1168A18	1
18	FRAME	5-0294A18	1
19	FUEL HOSE *(NINE FEET REQUIRED)	15-0008	1
20	CLAMP WORM	42-0004	4
21	BURNER FUEL TANK ASSEMBLY	N/A	1
22	FUEL TANK STRAP	20-1164A18	2
23	HOSE HANGER	20-1165A18	1
24	PLUG	39-0234	9
25	PLUG	39-0238	2
26	BATTERY TRAY	20-1135A18	1
27	BATTERY BOX	33-0093	1
28	BOLT	27-3062	2
29	GUN/ WAND HOLDER	20-1166A18	2
30	HIGH PRESSURE HOSE	15-0202	1
31	BOLT	27-0020	4
32	WASHER	28-0022	14
33	BOLT	27-0122	7
34	HEAT EXCHANGER ASSEMBLY	N/A	1
35	LOCKNUT	30-0159	7
*MUST ORDER IN ONE FOOT LENGTHS			

# HDB ISOLATION PLATE

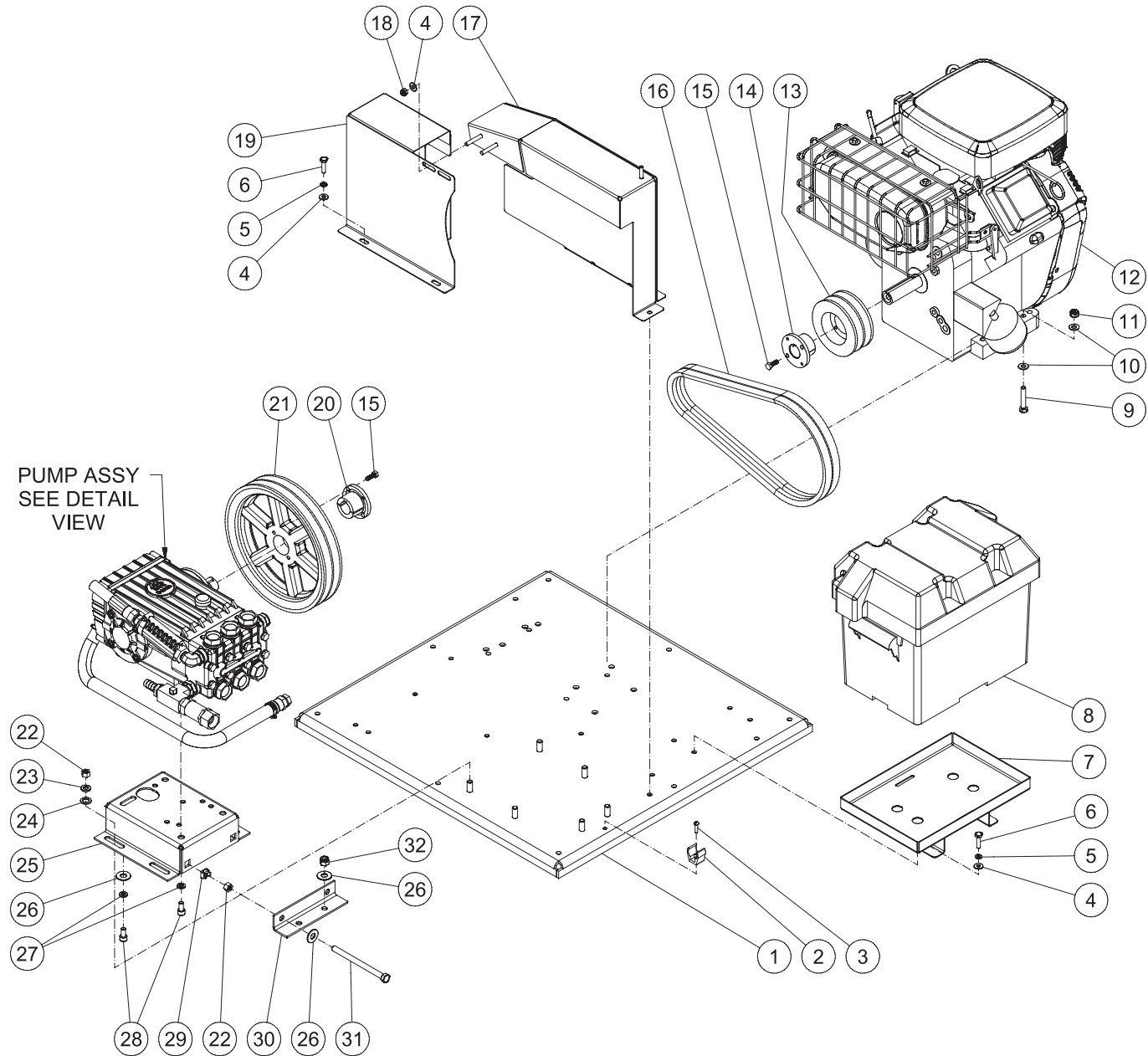

HDB ISOLATION PLATE 121809 CH



HDB ISOLATION PLATE 121809-CH			
HDB ISOLATION PLATE			
ITEM	DESCRIPTION	Mi-T-M #	QTY
1	ISOLATION PLATE	5-0296A18	1
2	HOSE CLIP	62-0209	1
3	SCREW	27-2811	1
4	WASHER	28-0002	12
5	LOCKWASHER	29-0006	10
6	BOLT	27-0016	10
7	BATTERY TRAY	20-1135A18	1
8	BATTERY BOX	33-0093	1
9	BOLT (HDB-3005-0V6G)	27-0070	4
-	BOLT (HDB-3005-0K6G)	27-0120	4
10	WASHER (HDB-3005-0V6G)	28-0003	8
-	WASHER (HDB-3005-0K6G)	28-0023	8
11	LOCKNUT (HDB-3005-0V6G)	30-0157	4
-	LOCKNUT (HDB-3005-0K6G)	30-0159	4
12	ENGINE - 16HP VANGUARD (HDB-3005-0V6G)	850-0392	1
-	ENGINE - 18HP KOHLER (HDB-3005-0K6G)	850-0332	1
13	SHEAVE	10-0125	1
14	BUSHING (HDB-3005-0V6G)	9-0005	1
-	BUSHING (HDB-3005-0K6G)	9-0010	1
15	BOLT	27-0015	4
16	BELT	11-0049	2
17	PUMP BELTGUARD	6-0092A18	1
18	LOCKNUT	30-0155	2
19	ENGINE BELTGUARD	6-0147A18	1
20	BUSHING	9-0017	1
21	SHEAVE	10-0037	1
22	NUT	30-0006	6
23	LOCKWASHER	29-0008	4
24	WASHER	28-0030	4
25	PUMP HAT	5-0153A18	1
26	WASHER	28-0023	5
27	LOCKWASHER	29-0054	4
28	BOLT	27-8884	4
29	CLIP NUT	30-6025	2
30	TENSION BRACKET	20-0584A18	1
31	BOLT	27-0133	2
32	LOCKNUT	30-0159	2

# HDD 3804 ISOLATION PLATE

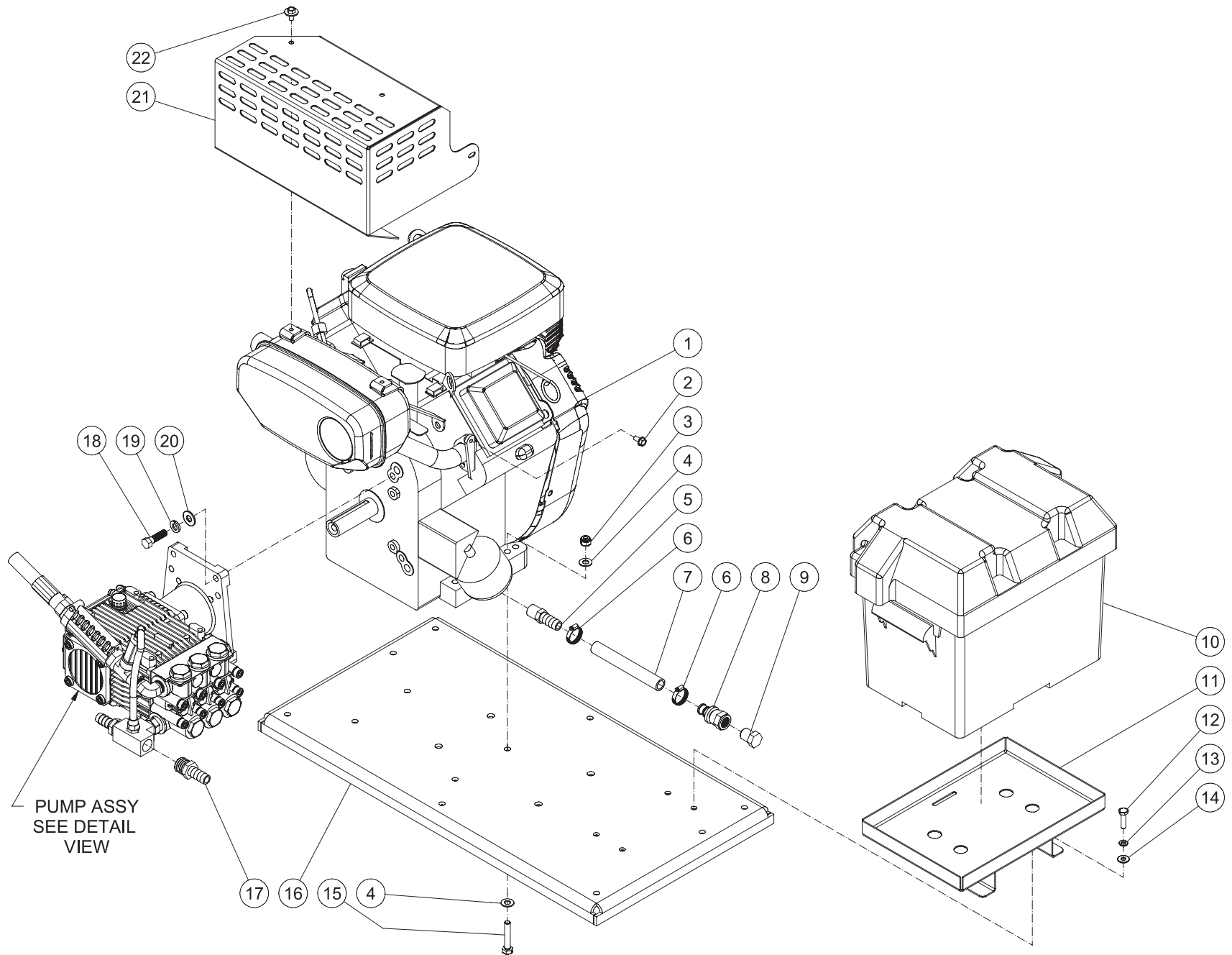

HDD-3804-0V6A ISOLATION PLATE-121809-CH

PUMP ASSY  
SEE DETAIL  
VIEW

HDD-3804-0V6A ISOLATION PLATE ASSY 121809-CH			
HDD 3804 ISOALTION PLATE			
ITEM	DESCRIPTION	Mi-T-M #	QTY
1	ENGINE - 16HP VANGUARD	1-0138	1
2	BOLT	27-8966	1
3	LOCKNUT	30-0157	4
4	WASHER	28-0003	8
5	HOSE BARB	23-0105	1
6	HOSE CLAMP	42-0011	2
7	HOSE *(TWO FEET REQUIRED)	15-0007	1
8	HOSE BARB	23-0360	1
9	PLUG	23-0411	1
10	BATTERY BOX	33-0093	1
11	BATTERY TRAY	20-1135A18	1
12	BOLT	27-0016	4
13	LOCKWASHER	29-0006	4
14	WASHER	28-0002	4
15	BOLT	27-0070	4
16	ISOLATION PLATE	5-0295A18	1
17	BARB	23-0045	1
18	BOLT	27-0118	4
19	LOCKWASHER	29-0008	4
20	WASHER	28-0022	4
21	HEAT SHIELD	20-1183	1
22	BOLT	27-8967	2
*MUST ORDER IN ONE FOOT LENGTHS			

# HDD 3504 ISOLATION PLATE

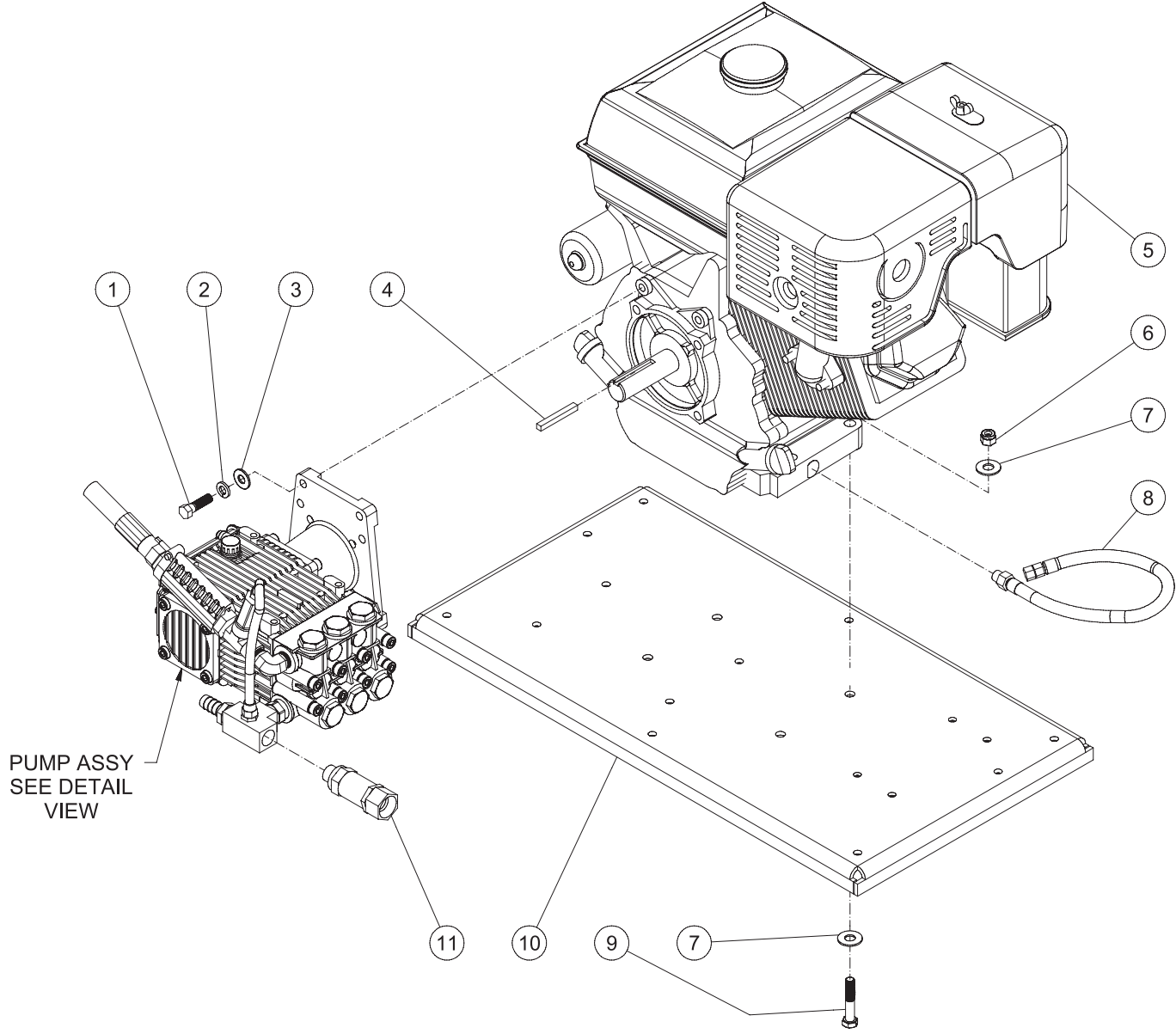

HDD-3504-0H6A ISOLATION PLATE-121809-CH

HDD-3504-0H6A ISO PLATE ASSY 121809 CH			
HDD 3504 ISOLATION PLATE			
ITEM	DESCRIPTION	Mi-T-M #	QTY
1	BOLT	27-0118	4
2	LOCKWASHER	29-0008	4
3	WASHER	28-0022	4
4	KEY	43-0078	1
5	ENGINE	1-0191	1
6	LOCKNUT	30-0159	4
7	WASHER	28-0023	8
8	OIL DRAIN HOSE	70-0358	1
9	BOLT	27-0121	4
10	ISOLATION PLATE	5-0295A18	1
11	FILTER	19-0206	1

# HDB PUMP PLUMBING

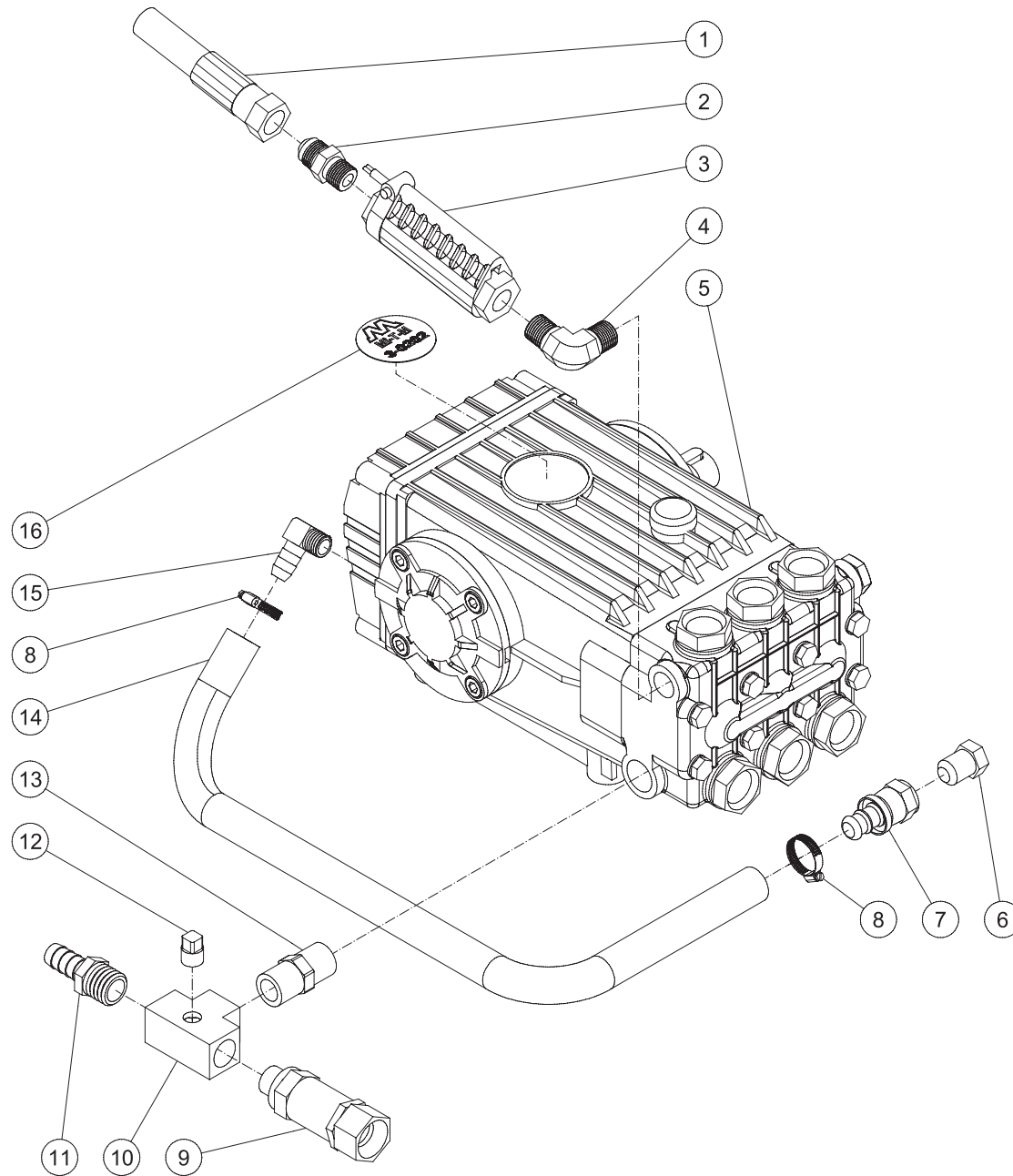

HDB PUMP PLUMBING 121809-CH

HDB PUMP PLUMBING 121809-CH			
HDB PUMP PLUMBING			
ITEM	DESCRIPTION	Mi-T-M #	QTY
1	HIGH PRESSURE HOSE ASSEMBLY	15-0221	1
2	NIPPLE	24-0002	1
3	FLOW SWITCH	22-0428	1
4	ELBOW	24-0131	1
5	PUMP	3-0202	1
6	PLUG	23-0411	1
7	HOSE BARB	23-0360	1
8	HOSE CLAMP	42-0011	2
9	FILTER	19-0206	1
10	TEE	23-0496	1
11	BARB	23-0045	1
12	PLUG	23-0238	1
13	NIPPLE	23-0012	1
14	HOSE *(TWO FEET REQUIRED)	15-0007	1
15	ELBOW	23-0119	1
16	DECAL - PUMP	34-2177	1
*MUST ORDER IN ONE FOOT LENGTHS			

# HDD PUMP PLUMBING

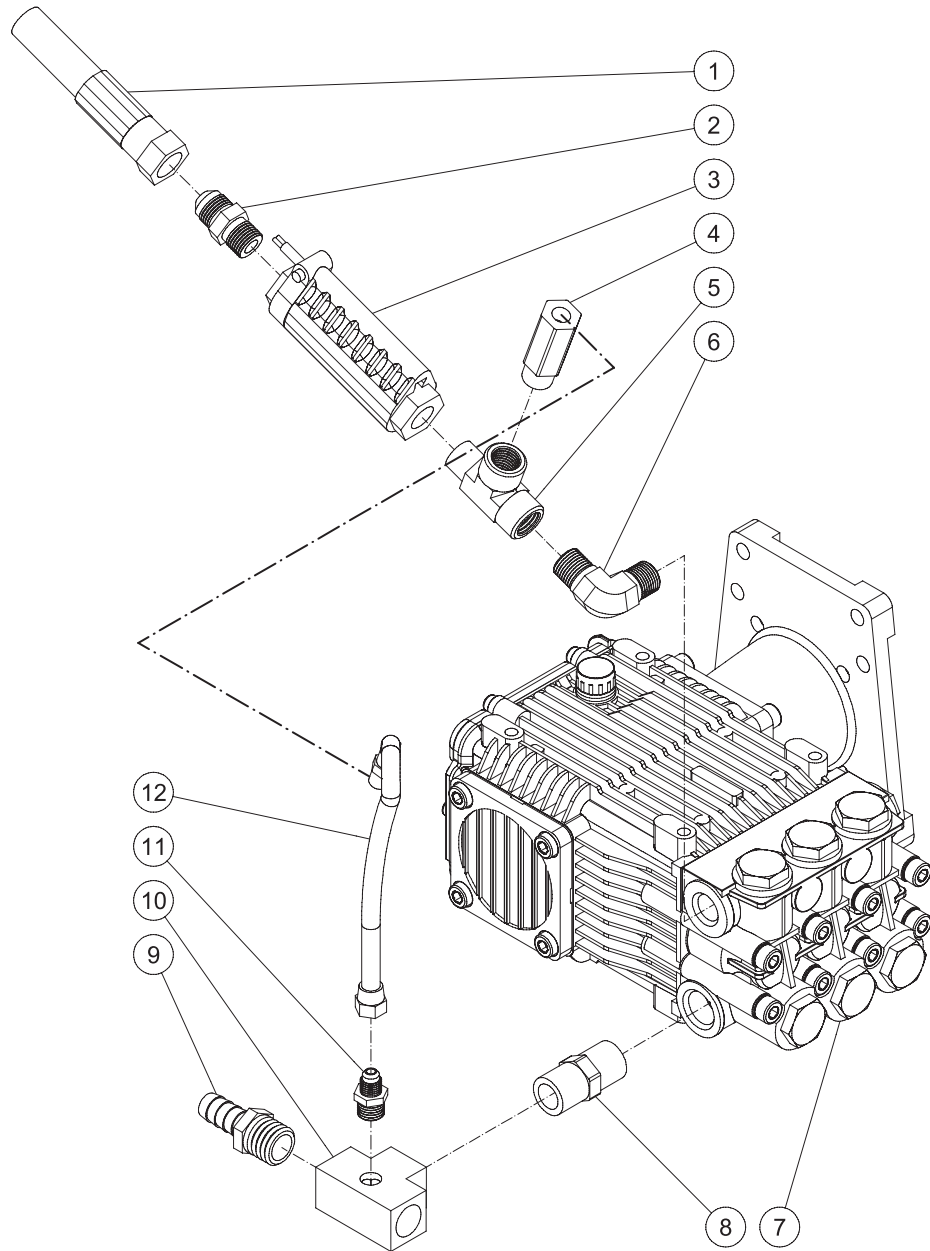



HDD PUMP PLUMBING 122109-CH			
HDD PUMP PLUMBING			
ITEM	DESCRIPTION	Mi-T-M #	QTY
1	HIGH PRESSURE HOSE ASSEMBLY	15-0221	1
2	NIPPLE	24-0002	1
3	FLOW SWITCH	22-0428	1
4	EASY START VALVE	22-0242	1
5	STREET TEE	23-0058	1
6	ELBOW	24-0131	1
7	PUMP (HDD-3504-0H6A)	3-0310	1
-	PUMP (HDD-3804-0V6A)	3-0208	1
8	NIPPLE	23-0012	1
9	BARB	23-0045	1
10	TEE	23-0496	1
11	NIPPLE	23-0247	1
12	EASY START HOSE	15-0140	1

# ENGINE ASSEMBLY (850-0392)

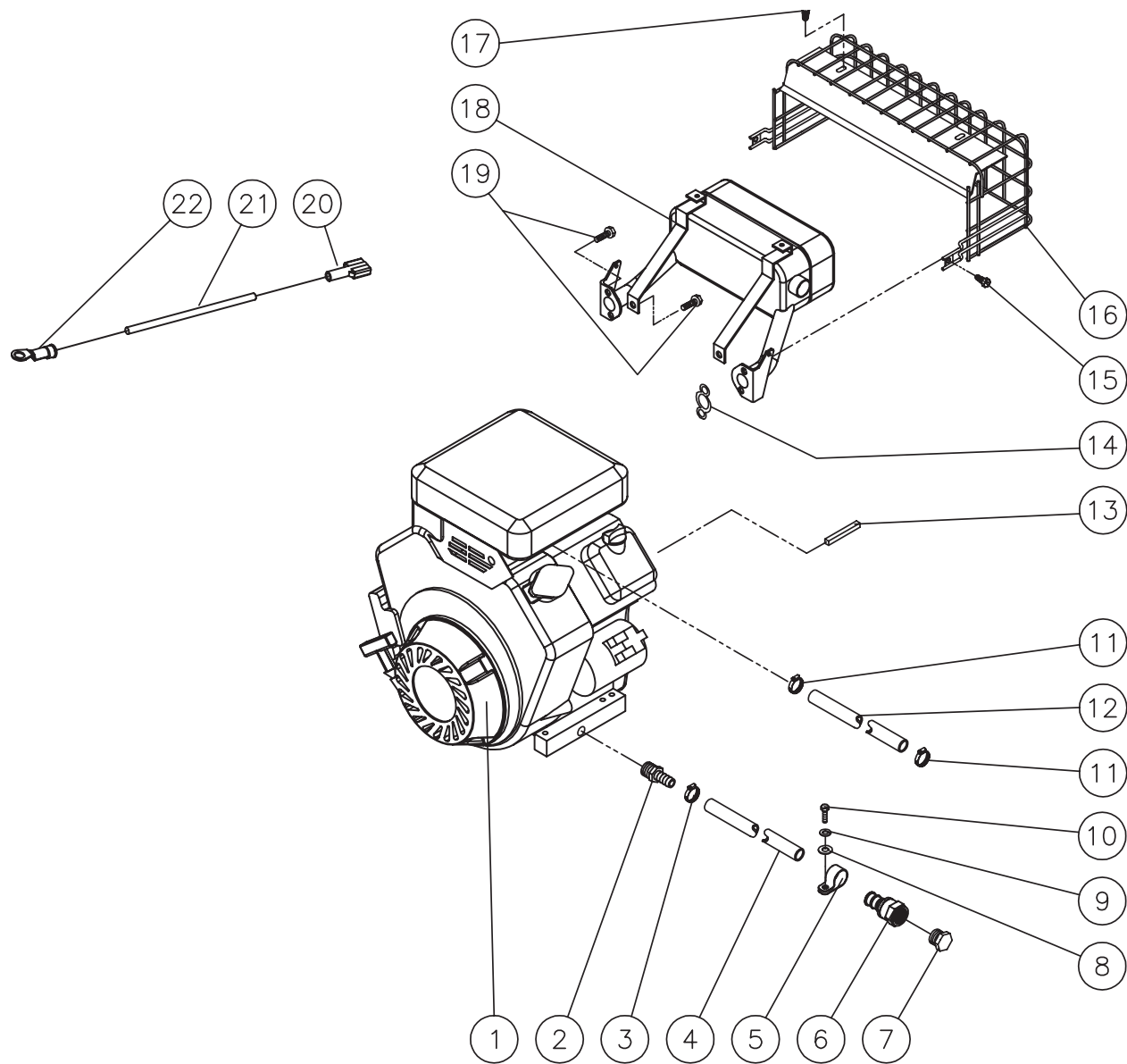

850-0392-011410-CH

## ENGINE ASSEMBLY (850-0392)

REF #	DESCRIPTION	PART #	QTY	REF #	DESCRIPTION	PART #	QTY
1	Engine- 16 HP Vanguard	1-0138	1	12	Hose *(Six Feet Required)	15-0008	1
2	Hose Barb	23-0105	1	13	Key	43-0078	1
3	Clamp Worm	42-0011	1	14	Gasket w/Muffler	45-0066	2
4	Hose *(One Foot Required)	15-0007	1	15	Screw	27-8966	2
5	Tube Clip	33-0291	1	16	Muffler Guard w/Muffler	45-0067	1
6	Hose Barb	23-0360	1	17	Screw w/Washer	27-8967	2
7	Plug	23-0411	1	18	Muffler	45-0064	1
8	Washer	28-0002	1	19	Screw w/Muffler	27-8968	4
9	Lockwasher	29-0006	1	20	Terminal	32-0221	1
10	Screw	27-0015	1	21	Wire- Red *(Three Feet Required)	32-0092	1
11	Clamp Worm	42-0004	2	22	Terminal Ring	32-0099	1

\*Must Order in One Foot Lengths

# ENGINE ASSEMBLY (850-0332)

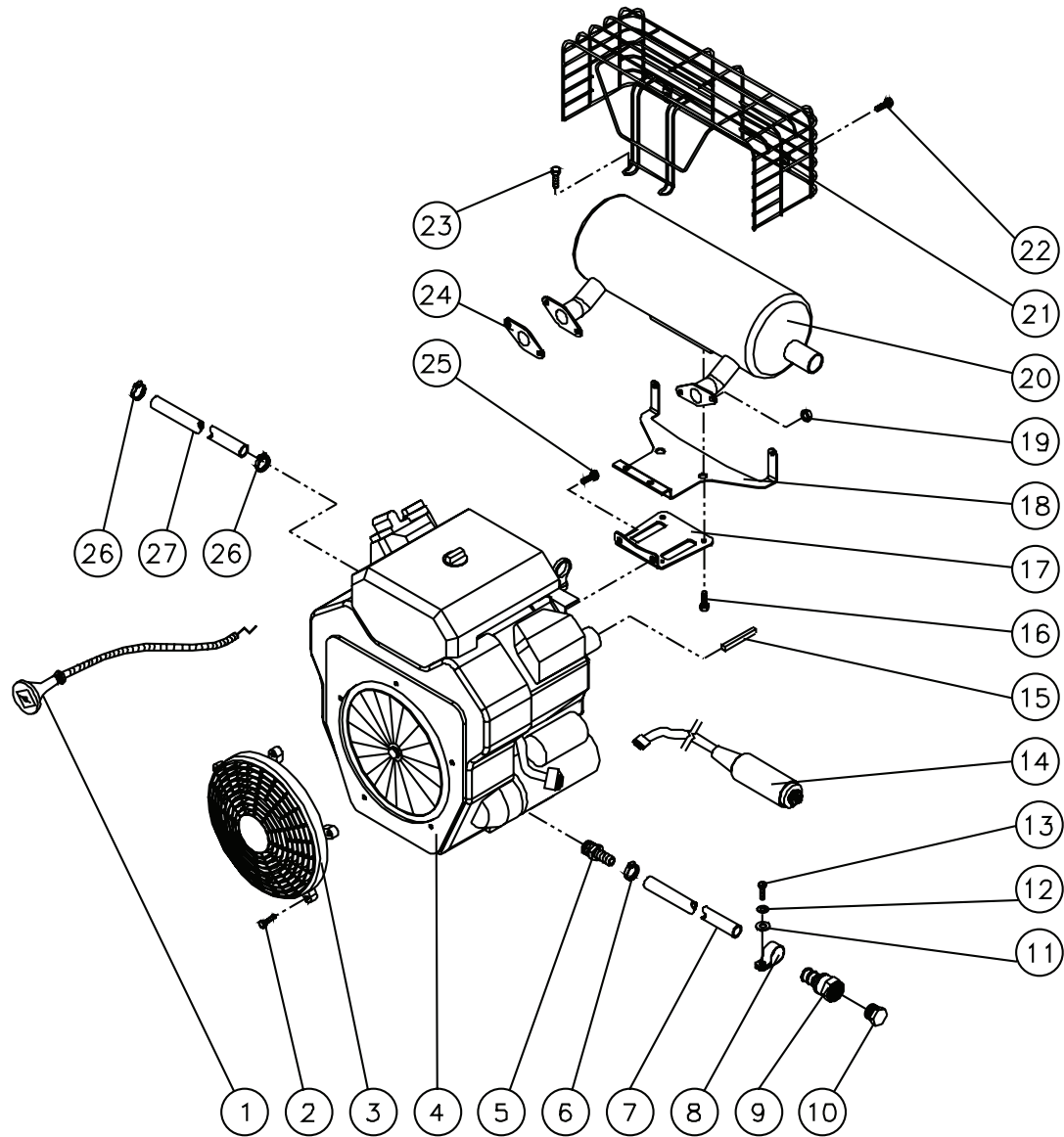

850-0332-042103-KZ

## ENGINE ASSEMBLY (850-0332)

REF #	DESCRIPTION	PART #	QTY	REF #	DESCRIPTION	PART #	QTY
1	Choke Cable	33-0081	1	15	Key	43-0078	1
2	Bolt (See 45-0072)	N/A Sep.	5	16	Bolt (See 45-0073)	N/A Sep.	2
3	Blower Housing Front Guard w/Engine	45-0072	1	17	Muffler Support (See 45-0073)	N/A Sep.	1
4	Engine- 18HP Kohler	1-0140	1	18	Muffler Guard Support (See 45-0077)	N/A Sep.	1
5	Hose Barb	23-0105	1	19	Nut (See 45-0073)	N/A Sep.	4
6	Clamp Worm	42-0011	1	20	Canister Muffler	45-0073	1
7	Hose *(One Foot Required)	15-0007	1	21	Muffler Guard	45-0077	1
8	Tube Clip	33-0291	1	22	Bolt (See 45-0077)	N/A Sep.	2
9	Hose Barb	23-0360	1	23	Bolt (See 45-0077)	N/A Sep.	2
10	Plug	23-0411	1	24	Gasket (See 45-0073)	N/A Sep.	2
11	Washer	28-0002	1	25	Bolt (See 45-0073)	N/A Sep.	2
12	Lockwasher	29-0006	1	26	Clamp Worm	42-0004	2
13	Screw	27-0015	1	27	Hose *(Three Feet Required)	15-0008	1
14	Key Switch Assembly	850-0299	1	*Must Order in One Foot Lengths			

# PUMP ASSEMBLY (3-0202) (AFTER SERIAL #15045000)

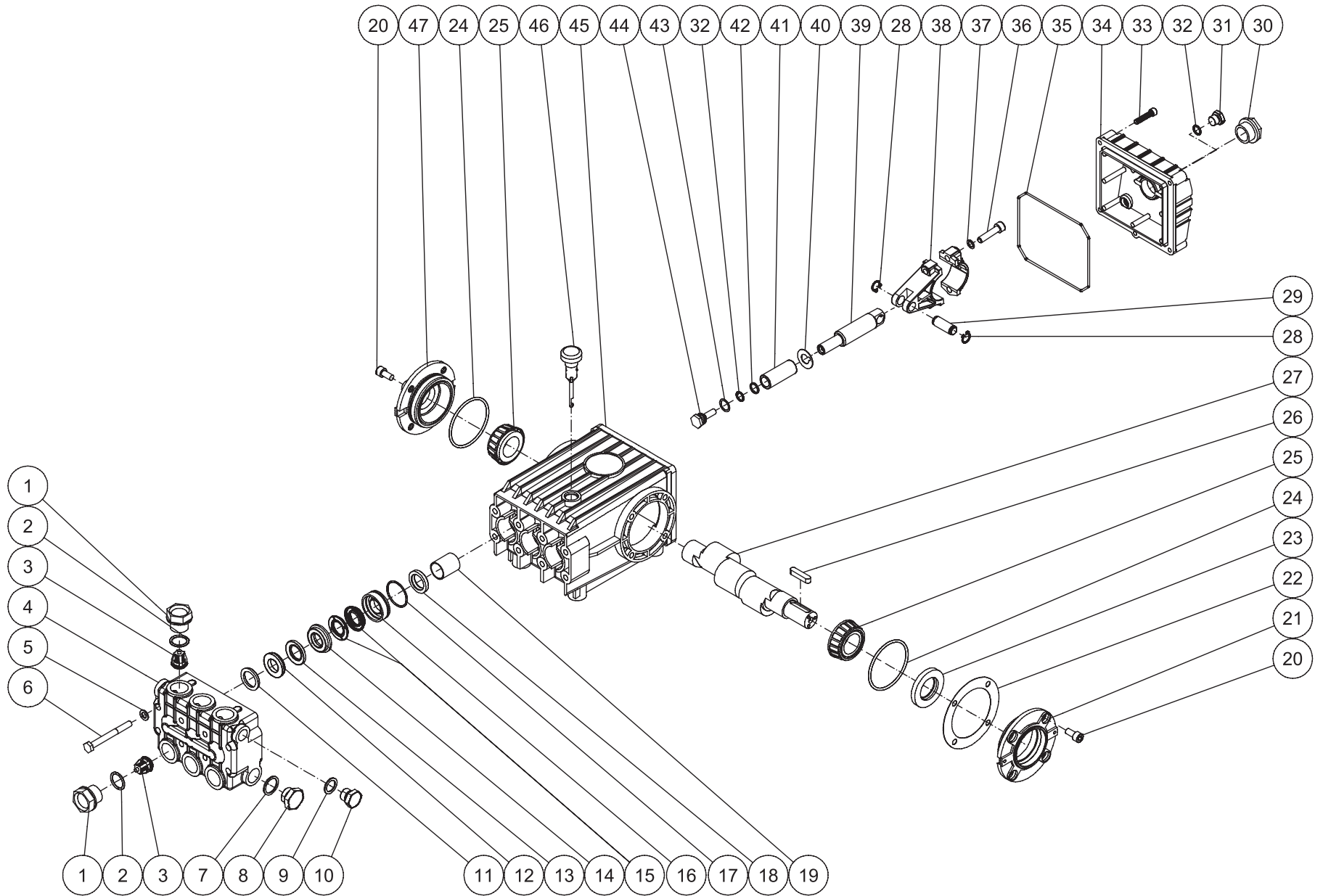

3-0202\_3-0203-010408-JJT

## PUMP ASSEMBLY

REF. #	DESCRIPTION	PART #	QTY.	REF. #	DESCRIPTION	PART #	QTY.	REF. #	DESCRIPTION	PART #	QTY.
1	Valve Plug	46-0889	6	18	Oil Seal	26-0047	3	35	O-ring Cover	25-0339	1
2	O-ring	25-0012	6	19	Bushing	9-0029	3	36	Bolt	27-8435	6
3	Valve Assembly (See 70-0009)	N/A Sep.	6	20	Bolt	27-8431	8	37	Lockwasher	29-0154	6
4	Manifold	46-0890	1	21	Crankcase Open Cover	46-0296	1	38	Connecting Rod	46-0051	3
5	Flatwasher	28-1039	8	22	Shim	46-0113	1	39	Piston Rod	46-0056	3
6	Bolt	27-8185	8	23	Oil Seal	26-0049	1	40	Washer	46-0146	3
7	Washer	28-1038	2	24	O-ring	25-0013	2	41	Plunger	46-0052	3
8	Plug	39-0019	2	25	Bearing	48-0012	2	42	Back-up Ring	46-0109	3
9	Washer	28-1002	2	26	Key	43-0048	1	43	Washer	28-0400	3
10	Plug	39-0018	2	27	Crankshaft	N/A	1	44	Bolt	46-0069	3
11	O-ring (See 70-0030)	N/A Sep.	3	28	Retaining Ring	46-0103	6	45	Crankcase	46-0047	1
12	V-Packing	26-0098	3	29	Connecting Rod Pin	43-0032	3	46	Oil Dip Stick	46-0144	1
13	Ring	25-0207	3	30	Oil Level Indicator	46-0114	1	47	Crankcase Cover	46-0336	1
14	High Pressure Intermediate Seal Retainer	46-0659	3	31	Plug	39-0017	1		Valve Kit (6 each 3)	70-0009	
15	Low Pressure Seal	N/A Sep.	3	32	O-ring	25-0014	4		Head Ring Kit (1 each 11)	70-0030	
16	Low Pressure Seal Retainer	46-0057	3	33	Bolt	27-8404	5		V-Packing Kit (3 each 12, 13, 15)	70-0147	
17	O-ring	25-0015	3	34	Crankcase Cover	46-0295	1		Intermediate Retainer Kit (3 each 13, 14)	70-0148	
									V-Packing Assembly (3 each 11-13, 15, 17)	852-0122	

# PUMP ASSEMBLY (3-0208)

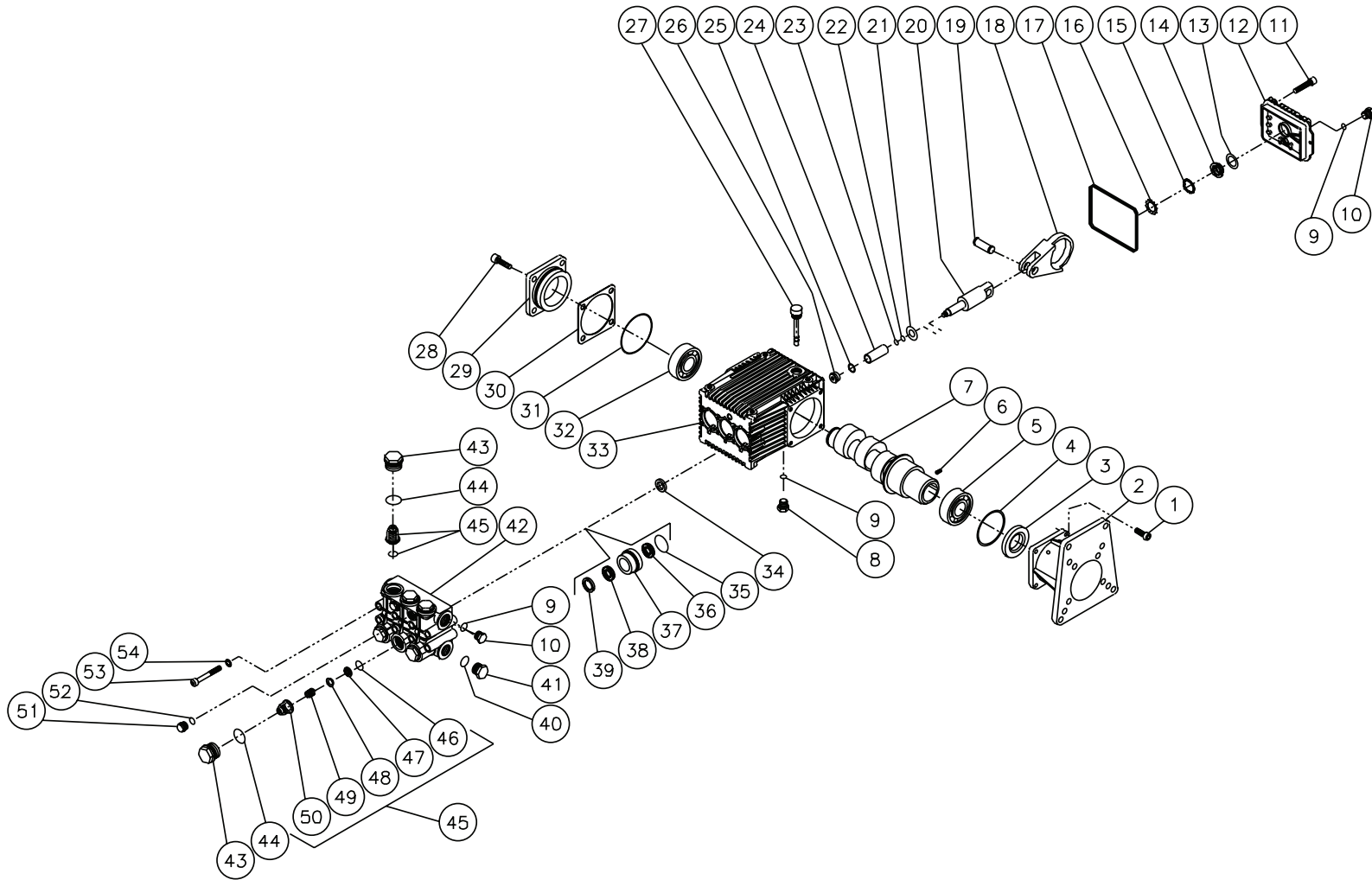

3-0208-030503-RD



## PUMP ASSEMBLY (3-0208)

REF. #	DESCRIPTION	PART #	QTY.	REF. #	DESCRIPTION	PART #	QTY.	REF. #	DESCRIPTION	PART #	QTY.
1	Bolt	27-8432	4	21	Washer	46-0700	3	41	Plug	39-0088	1
2	Flange	46-0714	1	22	Back-up Ring	25-0404	3	42	Manifold	46-0711	1
3	Oil Seal	26-0194	1	23	O-ring	25-0382	3	43	Valve Cap	39-0095	6
4	O-ring	25-0397	1	24	Piston	46-0701	3	44	O-ring	25-0160	6
5	Bearing	48-0062	1	25	Gasket	26-0191	3	45	Single Valve Assembly (Inc. 46-50) (See 70-0179)	N/A Sep.	6
6	Set Screw	27-8886	1	26	Nut	30-6020	3	46	O-ring	25-0386	6
7	Crankshaft	46-0895	1	27	Oil Dipstick	39-0090	1	47	Valve Seat (See 70-0179)	N/A Sep.	6
8	Plug	39-0102	1	28	Bolt	27-8884	4	48	Valve Plate (See 70-0179)	N/A Sep.	6
9	O-ring	25-0325	3	29	Support Bearing Cap	46-0703	1	49	Valve Spring (See 70-0179)	N/A Sep.	6
10	Plug	39-0086	2	30	Shim- 0.1mm (Qty. Varies 1-3)	46-0704	-	50	Valve Cage (See 70-0179)	N/A Sep.	6
11	Bolt	27-8885	6	-	Shim- 0.2mm (Qty. Varies 1-3)	46-0705	-	51	Plug	39-0096	2
12	Crankcase Cover	46-0719	1	31	O-ring	25-0380	1	52	O-ring	25-0387	2
13	O-ring	25-0370	1	32	Bearing	48-0072	1	53	Bolt	27-8440	8
14	Oil Sight Glass	46-0670	1	33	Crankcase	46-0811	1	54	Lockwasher	29-0154	8
15	Reflector	46-0824	1	34	Oil Seal	26-0190	3		High Pressure Seals Kit (Inc. 3 each 35, 36, 38)	70-0177	
16	Retainer	46-0671	1	35	O-ring	25-0384	3		Support Rings Kit (Inc. 3 each 39)	70-0178	
17	O-ring	25-0398	1	36	Low Pressure Seal (See 70-0177)	N/A Sep.	3		Valve Kit (Inc. 6 each 46-50)	70-0179	
18	Connecting Rod (Bronze)	46-0922	3	37	Packing Retainer	46-0708	3		Piston Kit (Inc. 3 each 21-26)	70-0352	
-	Connecting Rod (Aluminum)	46-0893	3	38	V-Packing (See 70-0177)	N/A Sep.	3		Oil Seals Kit (Inc. 3, 4, 17, 31, 34)	70-0337	
19	Piston Pin	46-0698	3	39	Support Ring (See 70-0178)	N/A Sep.	3				
20	Plunger Rod	46-0699	3	40	O-ring	25-0372	1				

# PUMP ASSEMBLY (3-0310)

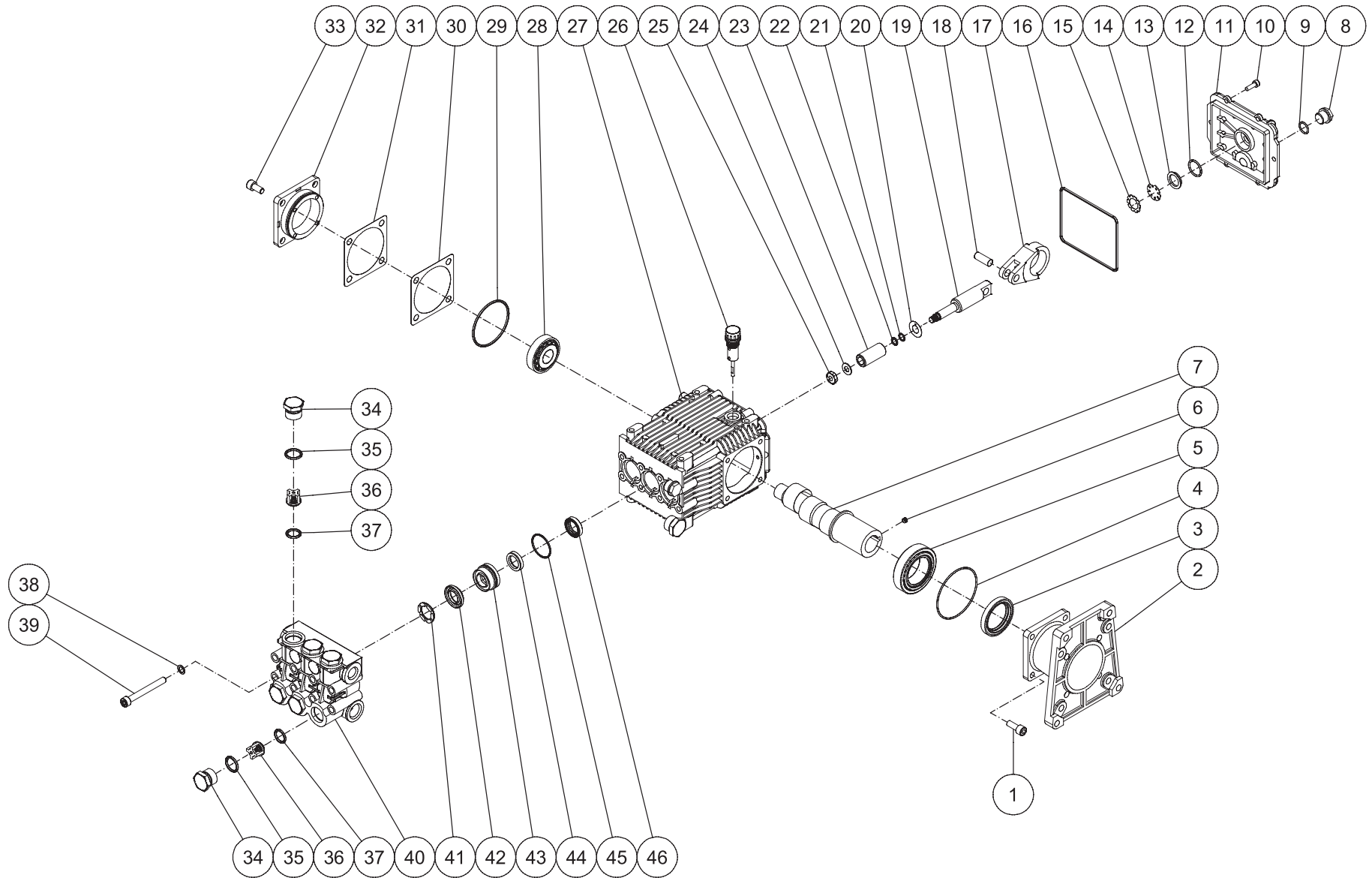

3-0310-011410-CH

PUMP (3-0310)							
ITEM	DESCRIPTION	Mi-T-M #	QTY	ITEM	DESCRIPTION	Mi-T-M #	QTY
1	SCREW	27-8432	4	28	BEARING	48-0072	1
2	PUMP FLANGE	46-0714	1	29	O-RING	25-0380	1
3	OIL SEAL	26-0194	1	30	SHIM (QTY VARIES 1-3)	46-0705	(1-3)
4	O-RING	25-0397	1	31	SHIM (QTY VARIES 1-3)	46-0704	(1-3)
5	BEARING	48-0062	1	32	BEARING CAP/SUPPORT	46-0703	1
6	BOLT	27-8886	1	33	BOLT	27-8884	4
7	CRANKSHAFT	46-0959	1	34	VALVE CAP	39-0095	6
8	PLUG	39-0086	2	35	O-RING	25-0160	6
9	O-RING	25-0325	2	36	VALVE	-	6
10	BOLT	27-8885	6	37	O-RING	25-0386	6
11	CRANKCASE COVER	46-0719	1	38	LOCKWASHER	29-0154	8
12	O-RING	25-0370	1	39	BOLT	27-8440	8
13	OIL SIGHT GLASS	46-0670	1	40	MANIFOLD	46-1186	1
14	OIL REFLECTOR	46-0824	1	41	SUPPORT RING	46-0710	3
15	SPRING RETAINER	46-0671	1	42	V PACKING	46-0709	3
16	O-RING	25-0398	1	43	PACKING RETAINER	46-0708	3
17	CONNECTING ROD	46-0922	3	44	LOW PRESSURE SEAL	46-0707	3
18	PISTON PIN	46-0698	3	45	O-RING	25-0384	3
19	PLUNGER ROD	46-0699	3	46	OIL SEAL	46-0931	3
20	SLINGER WASHER	46-0700	3	47	O-RING	25-0372	1
21	O-RING	25-0404	3	48	PLUG	39-0088	1
22	O-RING	25-0382	3		OIL SEALS KIT (INC. 3-4, 16, 29, 46)	70-0337	
23	PISTON	46-0701	3		PISTON KIT (INC. 3 EACH 20-25)	70-0352	
24	WASHER/GASKET	26-0191	3		HIGH PRESSURE SEALS KIT (INC. 3 EACH 42, 44, 45)	70-0177	
25	NUT	30-6020	3		SUPPORT RING KIT (INC. 3 EACH 41)	70-0178	
26	OIL DIPSTICK	39-0090	1		VALVE KIT (INC. 6 EACH 36-37)	70-0179	
27	CRANKCASE	46-1198	1				

## HDB GAS TANK ASSEMBLY

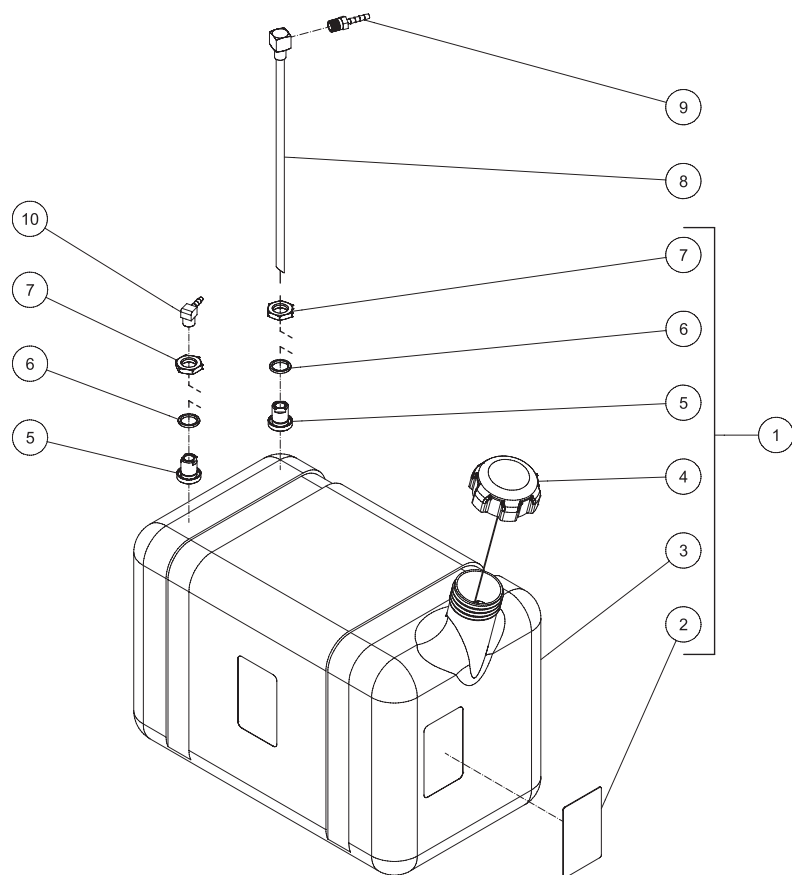

HDS GAS TANK ASSY 051012 CH			
GAS TANK ASSEMBLY			
ITEM	DESCRIPTION	PART #	QTY
1	GAS TANK ASSY (INC 2-7)	850-0306	1
2	DECAL- CAUTION: GASOLINE ONLY (SEE 71-0034)	N/A	1
3	FUEL TANK - RED	N/A	1
4	FUEL CAP - SEALED/TETHERED	12-0220	1
5	BULKHEAD FITTING	23-0408	2
6	O-RING	25-0427	2
7	NUT	23-0409	2
8	FUEL PICK-UP	33-0352	1
9	BARB	23-0051	1
10	ELBOW	23-0054	1

# BURNER FUEL TANK

HDC BURNER FUEL TANK ASSY-012606-JJT

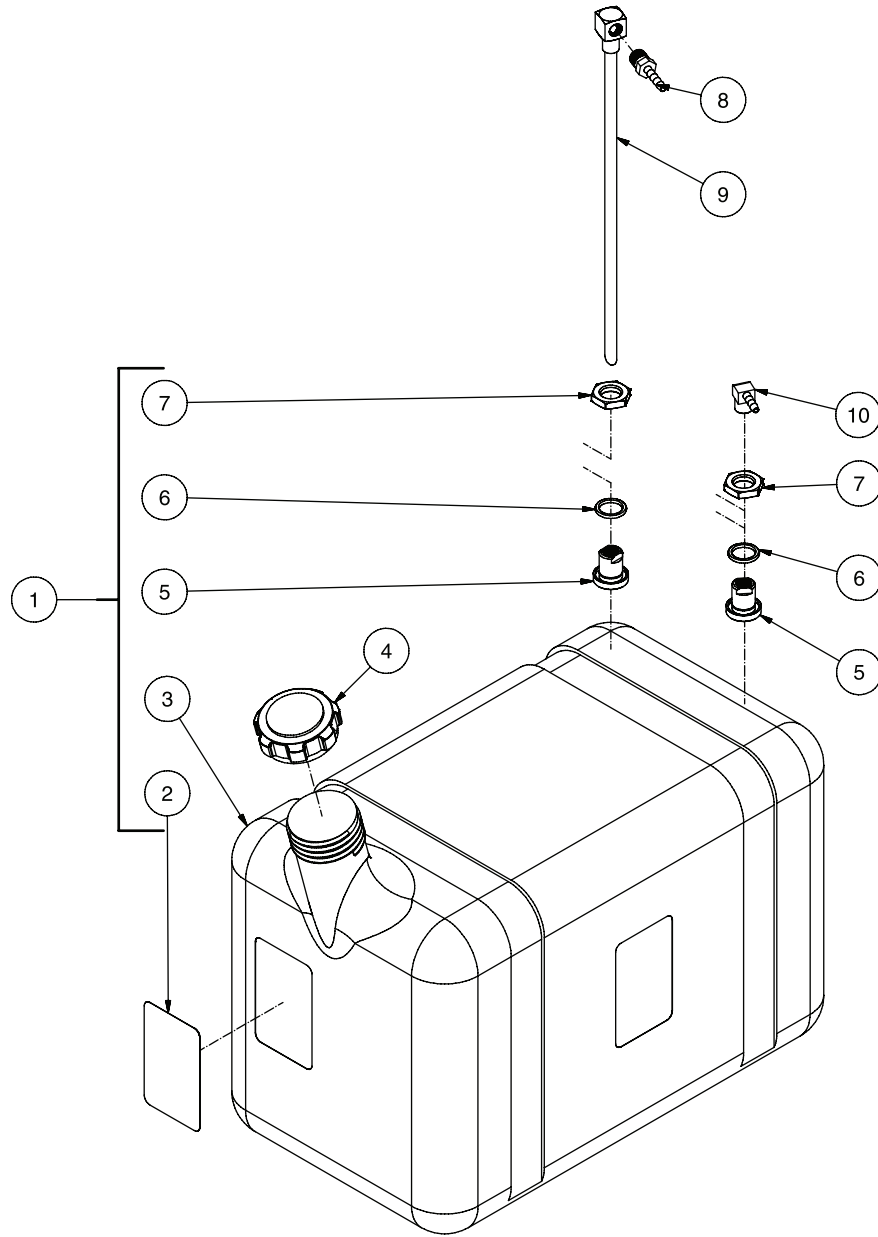

BURNER FUEL TANK			
REF. #	DESCRIPTION	PART #	QTY.
1	Fuel Tank Assembly (Inc. 2-3, 5-7)	850-0307	1
2	Decal- Caution: Risk of Fire (See 34-9024)	N/A Sep.	1
3	Fuel Tank (See 850-0307)	N/A Sep.	1
4	Fuel Cap	12-0033	1
5	Bulkhead Fitting	23-0408	2
6	O-ring	25-0427	2
7	Nut	23-0409	2
8	Hose Barb	23-0051	1
9	Fuel Pickup	33-0352	1
10	Elbow	23-0054	1
	Safety Decal Kit (Includes 2)	34-9024	

BURNER FUEL TANK ASSY-012606-JJT

# CONTROL PANEL ASSEMBLY

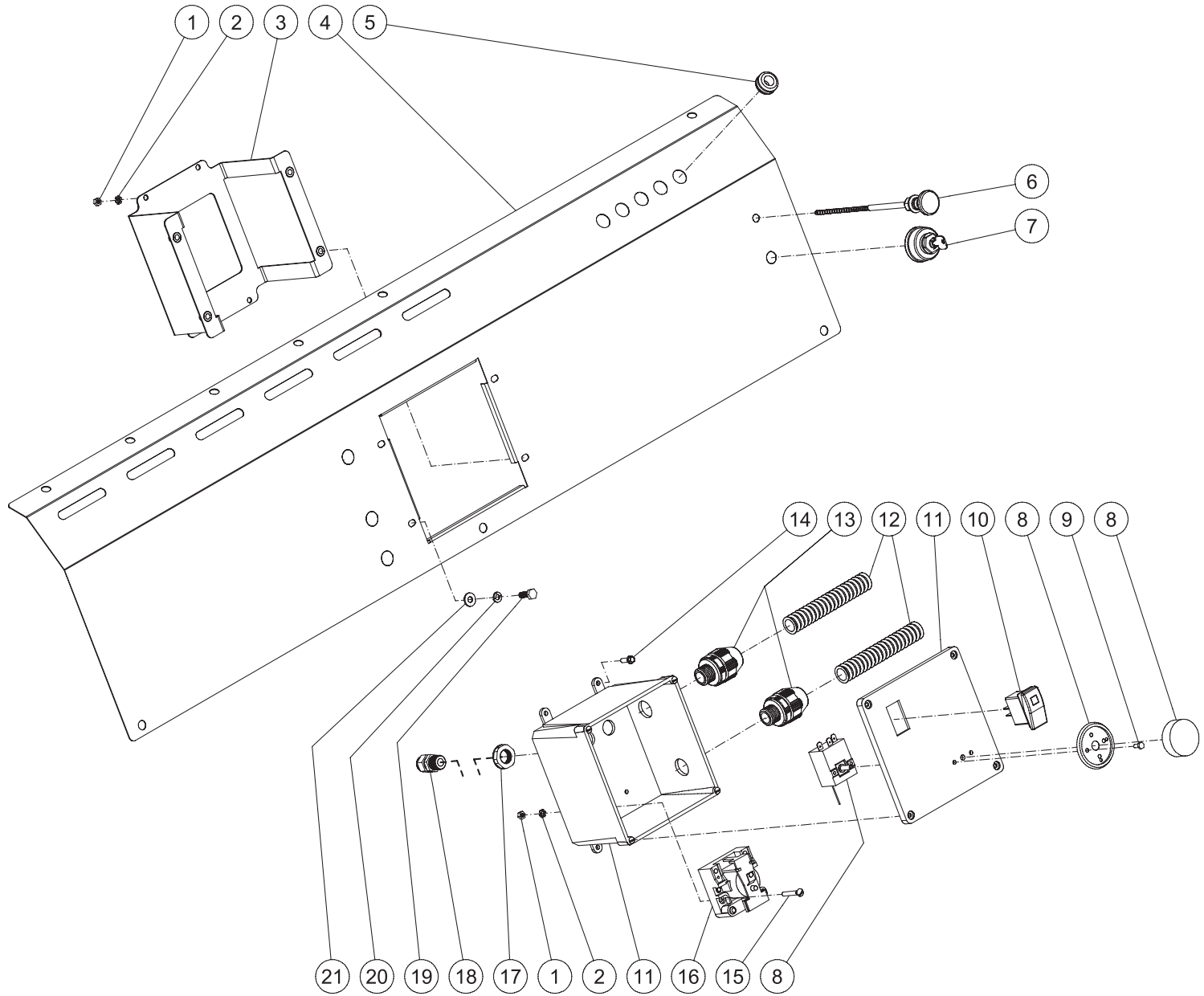

HDB\_HDD CONTROL PANEL-121809-CH

HDB_HDD CONTROL PANEL ASSY 121809-CH			
CONTOL PANEL ASSEMBLY			
ITEM	DESCRIPTION	Mi-T-M #	QTY
1	NUT	30-6001	6
2	STAR WASHER	28-1009	6
3	E-BOX BRACKET	20-1162A18	1
4	CONTROL PANEL	21-0291	1
5	GROMMET	33-0001	5
6	CHOKE CABLE (HDB-3005-0K6G)	33-0081	1
7	KEY SWITCH (HDB-3005-0K6G)	32-0699	1
8	ADJUSTABLE THERMOSTAT	32-0962	1
9	BOLT	27-8879	2
10	ROCKER SWITCH W/LAMP	32-0969	1
11	ELECTRICAL BOX	32-1064	1
12	CONDUIT FLEX *(SIX FEET REQUIRED)	32-0253	1
13	CONDUIT FITTING	32-0255	2
14	BOLT	27-9526	4
15	SCREW	27-8912	2
16	RELAY CONTROL	32-0791	1
17	ELECTRICAL LOCKNUT	32-0587	3
18	STRAIN RELIEF	32-0586	3
19	BOLT	27-0015	4
20	LOCKWASHER	29-0006	4
21	WASHER	28-0002	4
*MUST ORDER IN ONE FOOT LENGTHS			

# HDD HEAT EXCHANGER ASSEMBLY

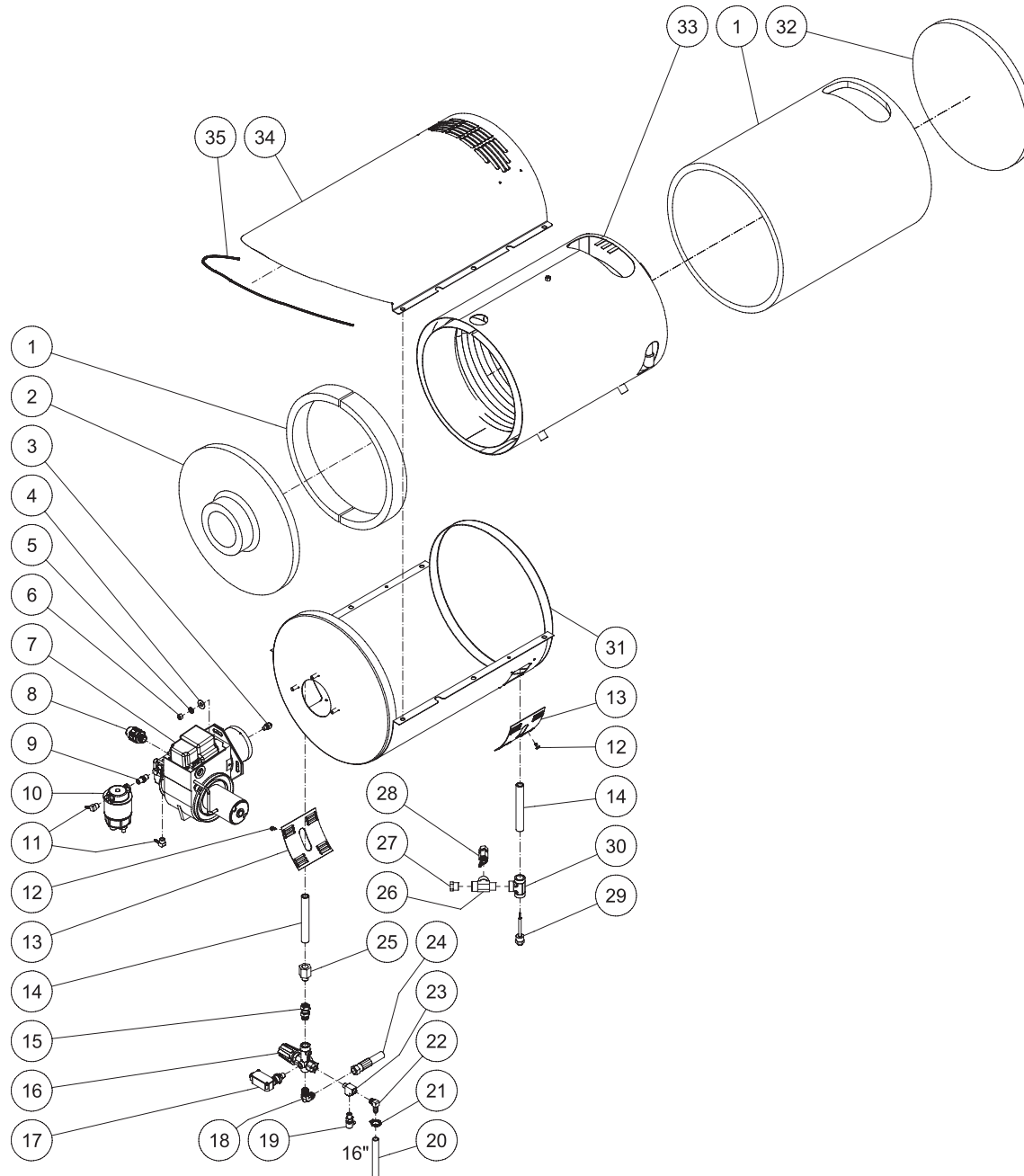

HDD HEAT EXCHANGER 072517 JRC



HDD HEAT EXCHANGER ASSY 072517 JRC			
HEAT EXCHANGER			
ITEM	DESCRIPTION	PART #	QTY
1	INSULATION BLANKET	850-0279	1
2	INSULATION DRUM HEAD	33-0345	1
3	FUEL NOZZLE	18-0091	1
4	WASHER	28-0023	3
5	LOCKWASHER	29-0008	3
6	NUT	30-0006	3
7	BURNER	4-0021	1
8	CONDUIT FITTING	32-0255	1
9	NIPPLE	24-0145	1
10	FUEL FILTER / WATER SEPERATOR	19-0070	1
11	ELBOW	23-0054	2
12	BOLT	27-3062	8
13	PATCH PLATE	20-0537A18	2
14	PIPE NIPPLE	24-0254	2
15	SWIVEL	24-0037	1
16	UNLOADER	850-0252	1
17	PRESSURE SWITCH	22-0243	1
18	ELBOW	24-0092	1
19	HEAT DUMP VALVE	22-0408	1
20	HOSE *(TWO FEET REQUIRED)	15-0007	1
21	HOSE CLAMP	42-0011	1
22	ELBOW	23-0119	1
23	TEE	23-0127	1
24	HIGH PRESSURE HOSE ASSEMBLY	15-0221	1
25	ADAPTER	24-0052	1
26	STREET TEE	24-0242	1
27	REDUCER BUSHING	23-0016	1
28	SAFETY RELIEF VALVE	22-0309	1
29	ADJUSTABLE THERMOSTAT	32-0962	1
30	TEE	24-0055	1
31	BOTTOM WRAP	20-0527A18	1
32	INSULATION DISC	33-0346	1
33	COIL	66-0014	1
34	TOP WRAP	21-0129	1
35	EDGING *(THREE FEET REQUIRED)	33-0020	1
*MUST ORDER IN ONE FOOT LENGTHS			

# HDB HEAT EXCHANGER ASSEMBLY

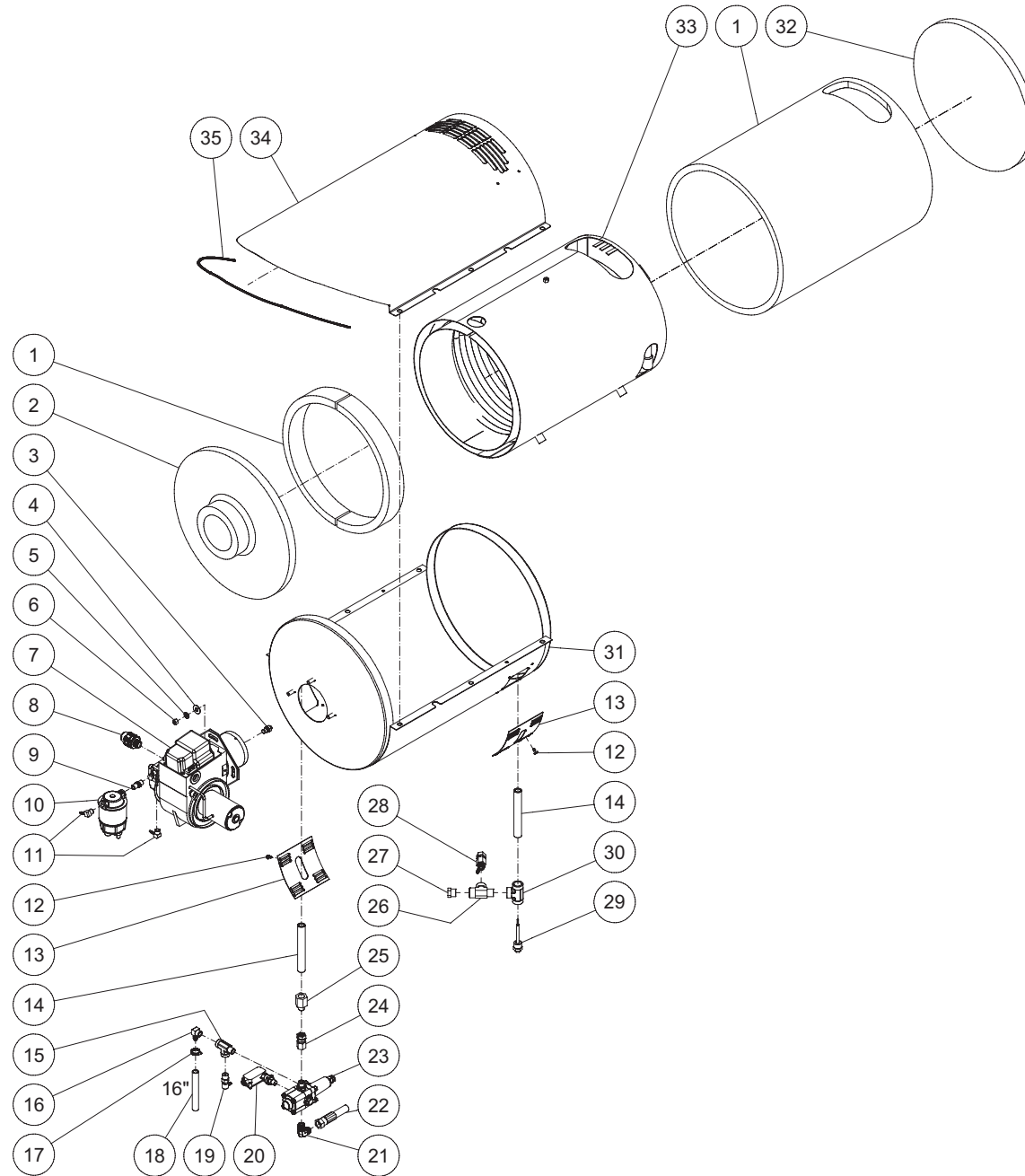

HDB HEAT EXCHANGER 072517 JRC

HDB HEAT EXCHANGER ASSY 072517 JRC			
HEAT EXCHANGER			
ITEM	DESCRIPTION	PART #	QTY
1	INSULATION BLANKET	850-0279	1
2	INSULATION DRUM HEAD	33-0345	1
3	FUEL NOZZLE	18-0090	1
4	WASHER	28-0023	3
5	LOCKWASHER	29-0008	3
6	NUT	30-0006	3
7	BURNER	4-0021	1
8	CONDUIT FITTING	32-0255	1
9	NIPPLE	24-0145	1
10	FUEL FILTER / WATER SEPERATOR	19-0070	1
11	ELBOW	23-0054	2
12	BOLT	27-3062	8
13	PATCH PLATE	20-0537A18	2
14	PIPE NIPPLE	24-0254	2
15	STREET TEE	23-0058	1
16	ELBOW	23-0050	1
17	HOSE CLAMP	42-0011	1
18	HOSE *(TWO FEET REQUIRED)	15-0007	1
19	HEAT DUMP VALVE	22-0432	1
20	PRESSURE SWITCH	22-0243	1
21	ELBOW	24-0092	1
22	HIGH PRESSURE HOSE ASSEMBLY	15-0221	1
23	UNLOADER (3005)	8-0013	1
-	UNLOADER (3004)	8-0012	1
24	SWIVEL	24-0016	1
25	ADAPTER	24-0052	1
26	STREET TEE	24-0242	1
27	REDUCER BUSHING	23-0016	1
28	SAFETY RELIEF VALVE	22-0309	1
29	ADJUSTABLE THERMOSTAT	32-0962	1
30	TEE	24-0055	1
31	BOTTOM WRAP	20-0527A18	1
32	INSULATION DISC	33-0346	1
33	COIL	66-0014	1
34	TOP WRAP	21-0129	1
35	EDGING *(THREE FEET REQUIRED)	33-0020	1
*MUST ORDER IN ONE FOOT LENGTHS			

# BURNER ASSEMBLY (4-0021)

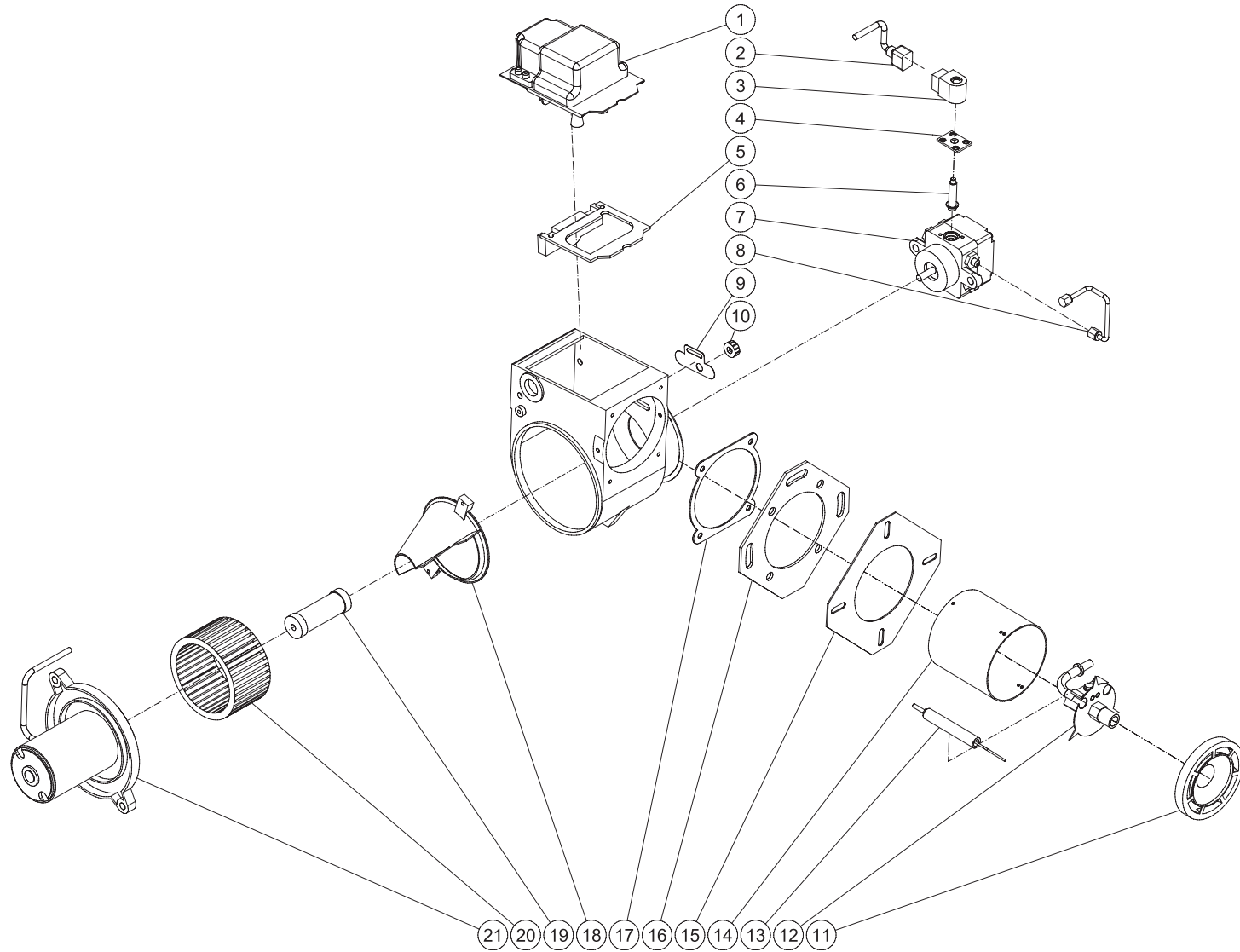

4-0021 032816 RJA

## BURNER ASSEMBLY

ITEM	DESCRIPTION	PART #	QTY
1	IGNITER ASSY W/ BASEPLATE	44-0125	1
2	CORD SET	44-0122	1
3	COIL	46-1015	1
4	TUBE BASE PLATE	46-1004	1
5	IGNITER GASKET KIT	70-0369	1
6	SOLENOID PISTON	46-1012	
7	FUEL PUMP	3-0434	1
8	TUBING	44-0025	1
9	PLATE	44-0031	1
10	NUT	44-0022	1
11	COMBUSTION HEAD	44-0011	1
12	ELECTRODE KIT	44-0111	1
13	ELECTRODE	44-0114	1
14	AIR TUBE	44-0110	1
15	FLANGE MOUNTING GASKET	44-0108	1
16	FLANGE	44-0109	1
17	GASKET FLANGE	26-0138	1
18	AIR GUIDE	44-0123	1
19	COUPLING	44-0127	1
20	BLOWER WHEEL	44-0124	1
21	MOTOR	2-0139	1

UNLOADER ASSEMBLY (850-0304)

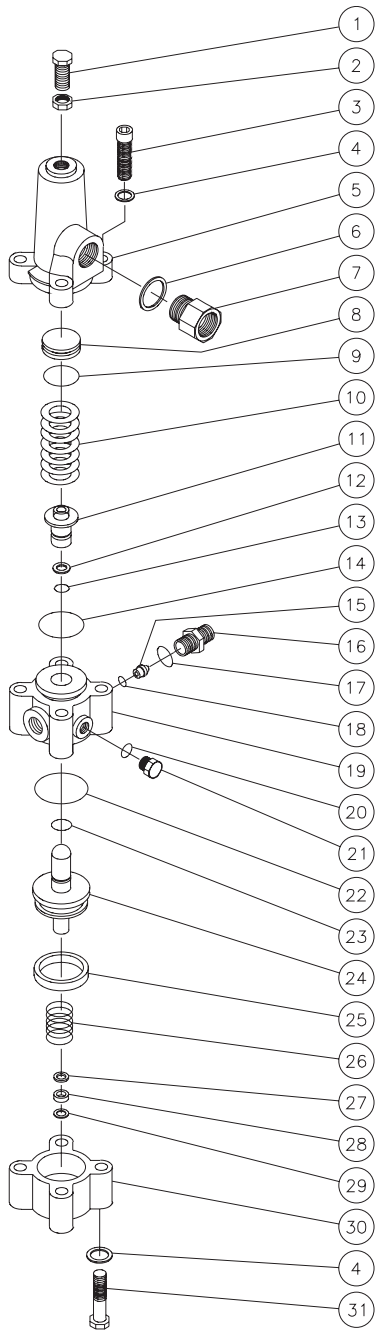

OMGEN066-040901-BAR

UNLOADER ASSEMBLY (850-0304)							
REF. #	DESCRIPTION	PART #	QTY.	REF. #	DESCRIPTION	PART #	QTY.
1	Bolt	27-8077	1	18	O-ring	25-0119	1
2	Hex Nut	30-3010	1	19	Middle Body	8-0137	1
3	Bolt	27-8434	4	20	O-ring	25-0114	2
4	Lockwasher	29-0154	8	21	Hex Plug	39-0017	2
5	Upper Body	8-0138	1	22	O-ring	25-0056	1
6	Washer	8-0277	1	23	O-ring	25-0120	1
7	By-Pass Restrictor	8-0124	1	24	Piston Assembly	8-0136	1
8	Spring Guide	8-0135	1	25	Seal	26-0104	1
9	O-ring	25-0118	1	26	Spring	49-0027	1
10	Spring	49-0026	1	27	Washer	8-0139	1
11	Valve Seat	8-0145	1	28	Seal	26-0105	1
12	Back-up Ring	8-0141	1	29	Back-up Ring	8-0140	1
13	O-ring	25-0121	1	30	Lower Body	8-0134	1
14	O-ring	25-0117	1	31	Bolt	27-8037	4
15	Flow Balancer (8-0012)	8-0126	1		Unloader Repair Kit (Inc. 9, 11, 13, 14, 17, 18, 20, 22-26, 28, 29)	70-0013	
-	Flow Balancer (8-0013)	8-0128	1		Unloader Orifice Kit (Inc. 1 each of 7, 15, 16)	852-0014	
-	Flow Balancer (8-0014, 850-0304)	8-0127	1		Unloader Orifice Kit (Inc. 1 each of 7, 15, 16)	852-0015	
16	Nipple(8-0014, 850-0304)	8-0131	1		Unloader Orifice Kit (Inc. 1 each of 7, 15, 16)	852-0017	
-	Nipple (8-0012, 8-0013)	8-0130	1		Unloader Orifice Kit (Inc. 1 each of 7, 15, 16)	852-0157	
17	O-ring	25-0052	1				

# UNLOADER ASSEMBLY (850-0252)

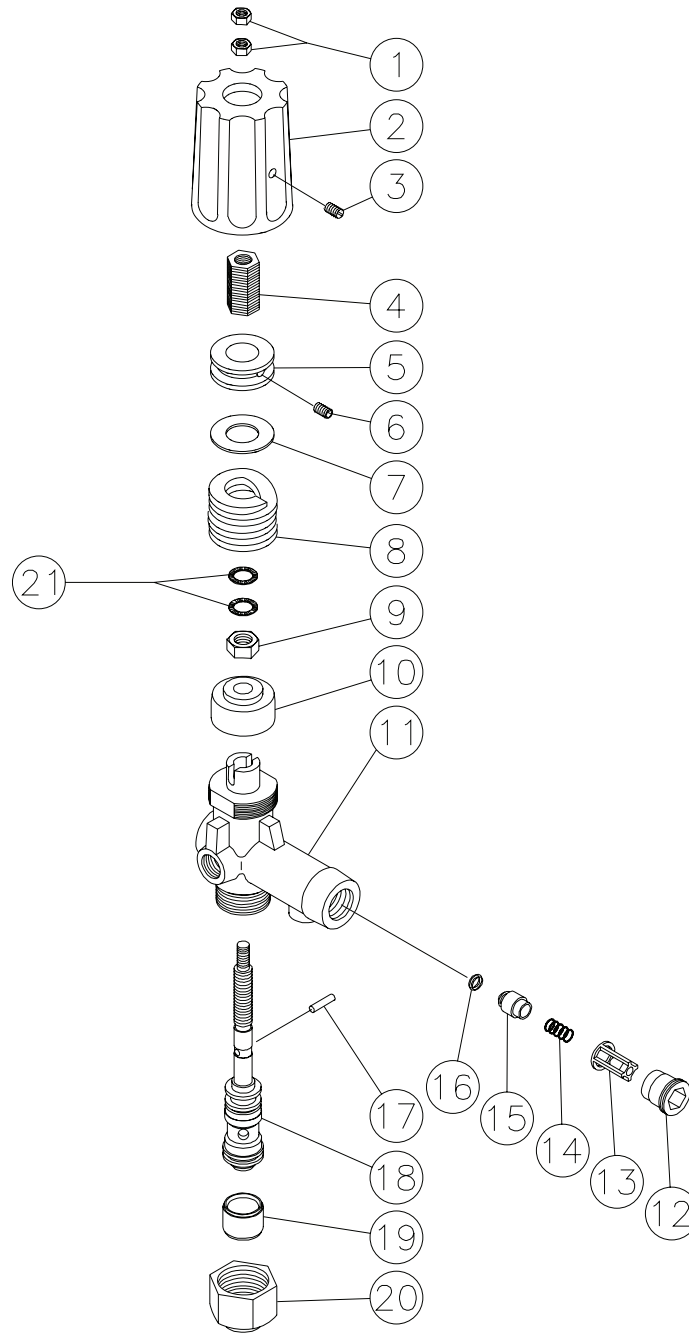



UNLOADER (850-0252)			
REF. #	DESCRIPTION	PART #	QTY.
1	Hex Nut	8-0362	2
2	Cover	7-0098	1
3	Set Screw	27-4280	1
4	Adjusting Insert- Brass	8-0363	1
5	Adjustment Nut	8-0364	1
6	Set Screw	8-0365	1
7	Glide Ring	8-0366	1
8	Spring	49-0104	1
9	Hex Nut	8-0367	1
10	Bushing	8-0368	1
11	Unloader Body	8-0369	1
12	Retainer	8-0269	1
13	Valve Housing	8-0104	1
14	Spring	49-0023	1
15	Valve	8-0105	1
16	O-ring	25-0036	1
17	Cylinder Pin	8-0372	1
18	Piston Repair Kit	70-0243	1
19	Spacer	8-0371	1
20	Stop Nut	8-0157	1
21	Washer	29-0154	2
	Check Valve Repair Kit (Includes 13-16)	70-0244	
	Unloader Complete	850-0252	

# PRESSURE SWITCH (22-0243)

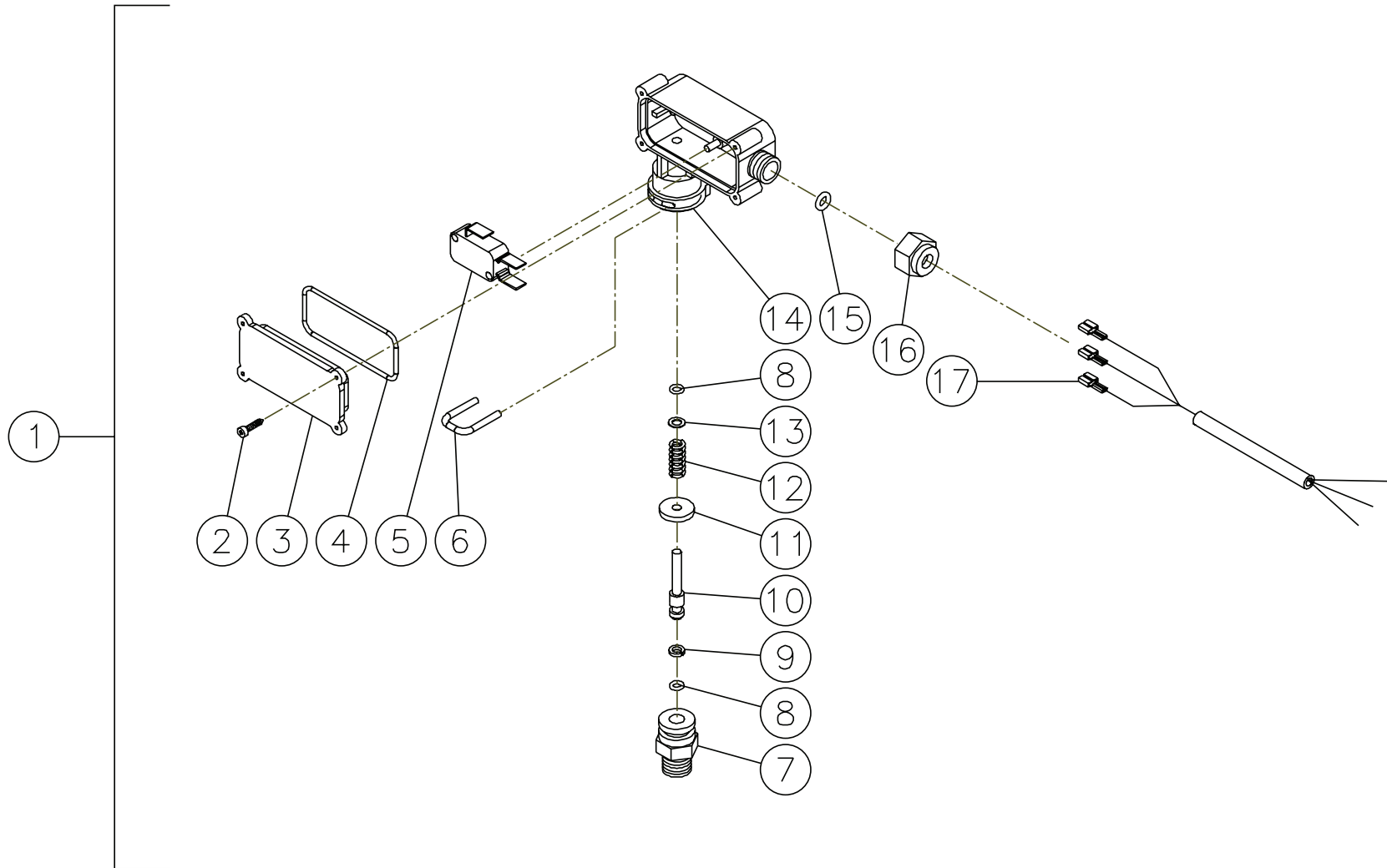

PRESSURE SWITCH								
REF. #	DESCRIPTION	PART #	QTY.		REF. #	DESCRIPTION	PART #	QTY.
1	Pressure Switch- 15 BAR	22-0171	1		11	Washer	N/A	1
-	Pressure Switch- 25 BAR	22-0243	1		12	Spring- 15 BAR	49-0144	1
2	Screw	N/A	4		-	Spring- 25 BAR	49-0145	1
3	Cover	N/A	1		13	Washer	N/A	1
4	O-ring (See 70-0306)	N/A Sep.	1		14	Plastic Housing	N/A	1
5	Micro Switch	N/A	1		15	O-ring (See 70-0306)	N/A Sep.	1
6	Retainer Clip	N/A	1		16	Nut- 15 BAR	N/A	1
7	Body	N/A	1		-	Nut- 25 BAR	N/A	1
8	O-ring (See 70-0306)	N/A Sep.	2		17	Wire Assembly	N/A	1
9	Back-up Ring (See 70-0306)	N/A Sep.	1			O-ring Repair Kit (Inc. 4, 8-9, 15)	70-0306	
10	Piston	N/A	1					

# GUN/WAND/HOSE ASSEMBLY

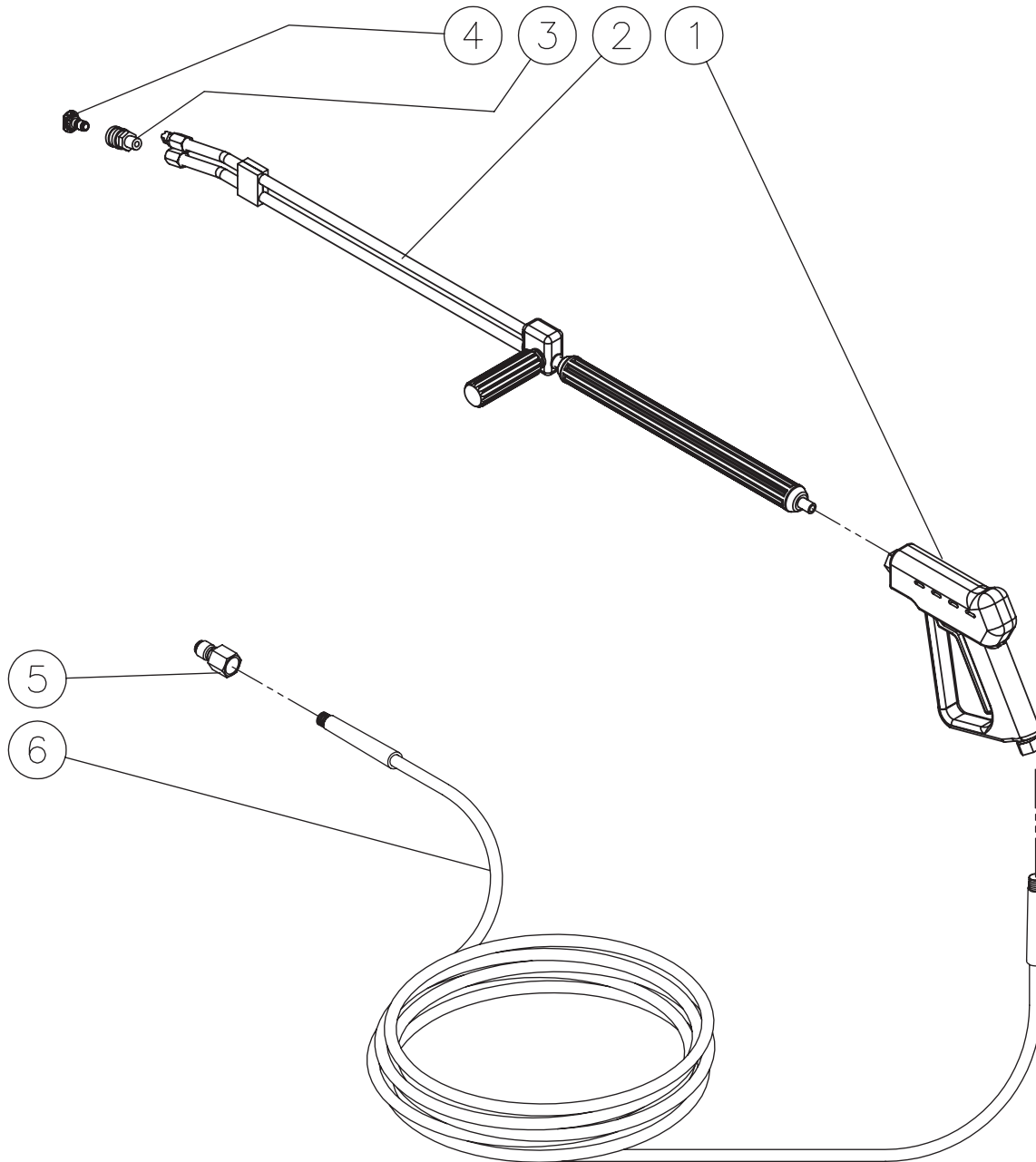

HDB\_HDD GUN WAND HOSE ASSEMBLY 071712-CH

HDB_HDD GUN/WAND/HOSE ASSY-071712-CH			
GUN/WAND/HOSE ASSEMBLY			
REF. #	DESCRIPTION	PART #	QTY.
1	Gun Assembly	16-0392	1
2	Dual Lance	16-0417	1
3	Quick Connect Socket	17-0028	1
4	Nozzle- 0004 (HDD-3804)	18-0397	1
-	Nozzle- 1504 (HDD-3804)	18-0399	1
-	Nozzle- 2504 (HDD-3804)	18-0400	1
-	Nozzle- 4004 (HDD-3804)	18-0401	1
-	Nozzle- 00035 (HDD-3504)	18-0392	1
-	Nozzle- 15035 (HDD-3504)	18-0393	1
-	Nozzle- 25035 (HDD-3504)	18-0395	1
-	Nozzle- 40035 (HDD-3504)	18-0396	1
-	Nozzle- 0005.5 (HDB-3005)	18-0410	1
-	Nozzle- 1505.5 (HDB-3005)	18-0411	1
-	Nozzle- 2505.5 (HDB-3005)	18-0412	1
-	Nozzle- 4005.5 (HDB-3005)	18-0413	1
5	Quick Connect Plug	17-0006	1
6	High Pressure Hose Assembly	15-0166	1

# GUN ASSEMBLY (16-0392)

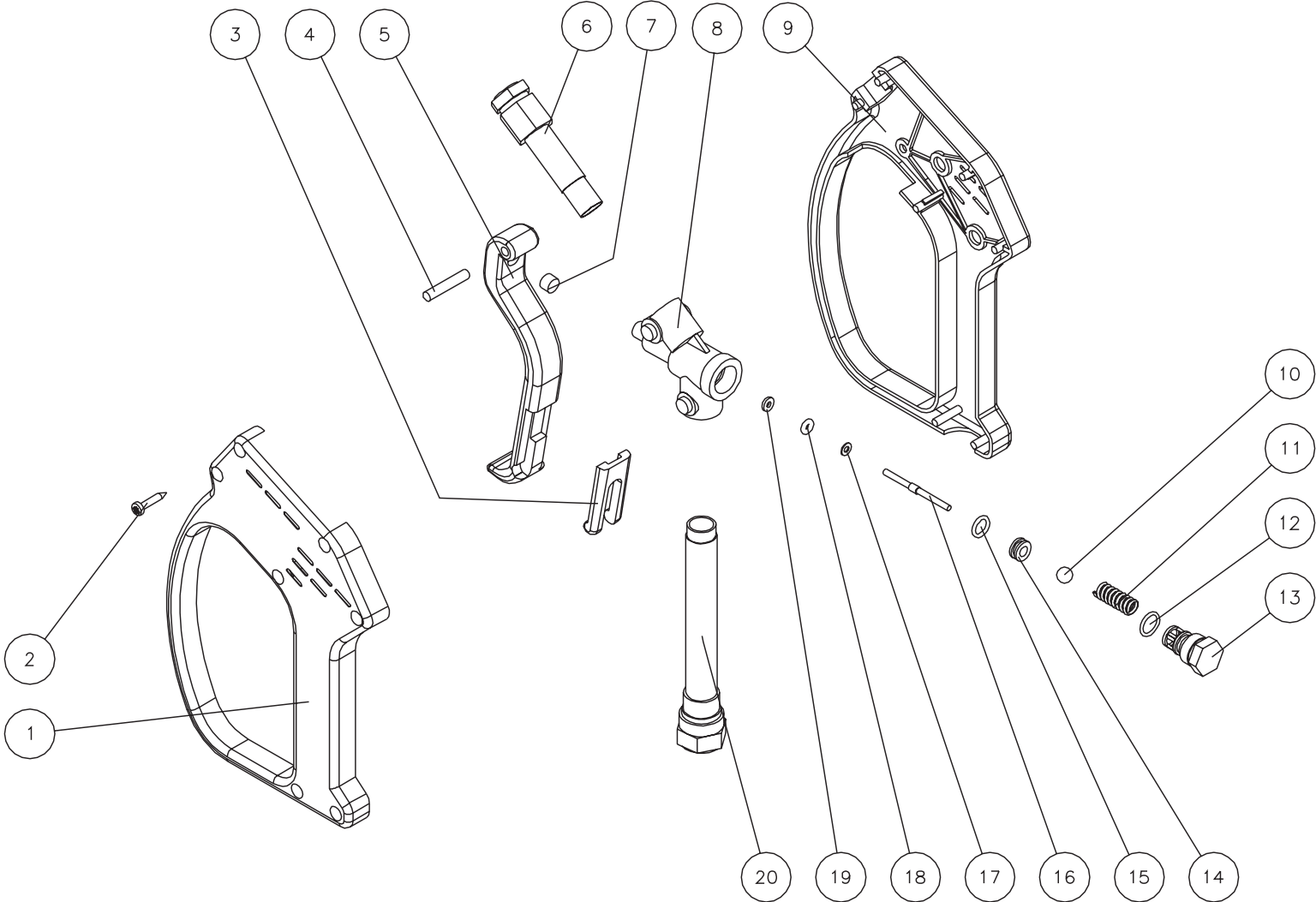

16-0392-030601-EDW

GUN ASSEMBLY (16-0392)								
REF. #	DESCRIPTION	PART #	QTY.		REF. #	DESCRIPTION	PART #	QTY.
1	Plastic Housing (Left)	N/A	1		12	O-ring (See 70-0332)	N/A Sep.	1
2	Screw	N/A	7		13	Spring Housing Plug	N/A	1
3	Safety Latch	N/A	1		14	Seat (See 70-0332)	N/A Sep.	1
4	Pin	N/A	1		15	O-ring (See 70-0332)	N/A Sep.	1
5	Trigger	16-0393	1		16	Piston (See 70-0332)	N/A Sep.	1
6	Tube	16-0395	1		17	Washer	N/A	1
7	Striker	16-0394	1		18	O-ring (See 70-0332)	N/A Sep.	1
8	Body	N/A	1		19	Back-up Ring (See 70-0332)	N/A Sep.	1
9	Plastic Housing (Right)	N/A	1		20	Tube	16-0396	1
10	Ball (See 70-0332)	N/A Sep.	1			Repair Kit (Inc. 10, 12, 14-16, 18, 19)	70-0332	1
11	Spring	N/A	1					

# DUAL LANCE ASSEMBLY (16-0417)

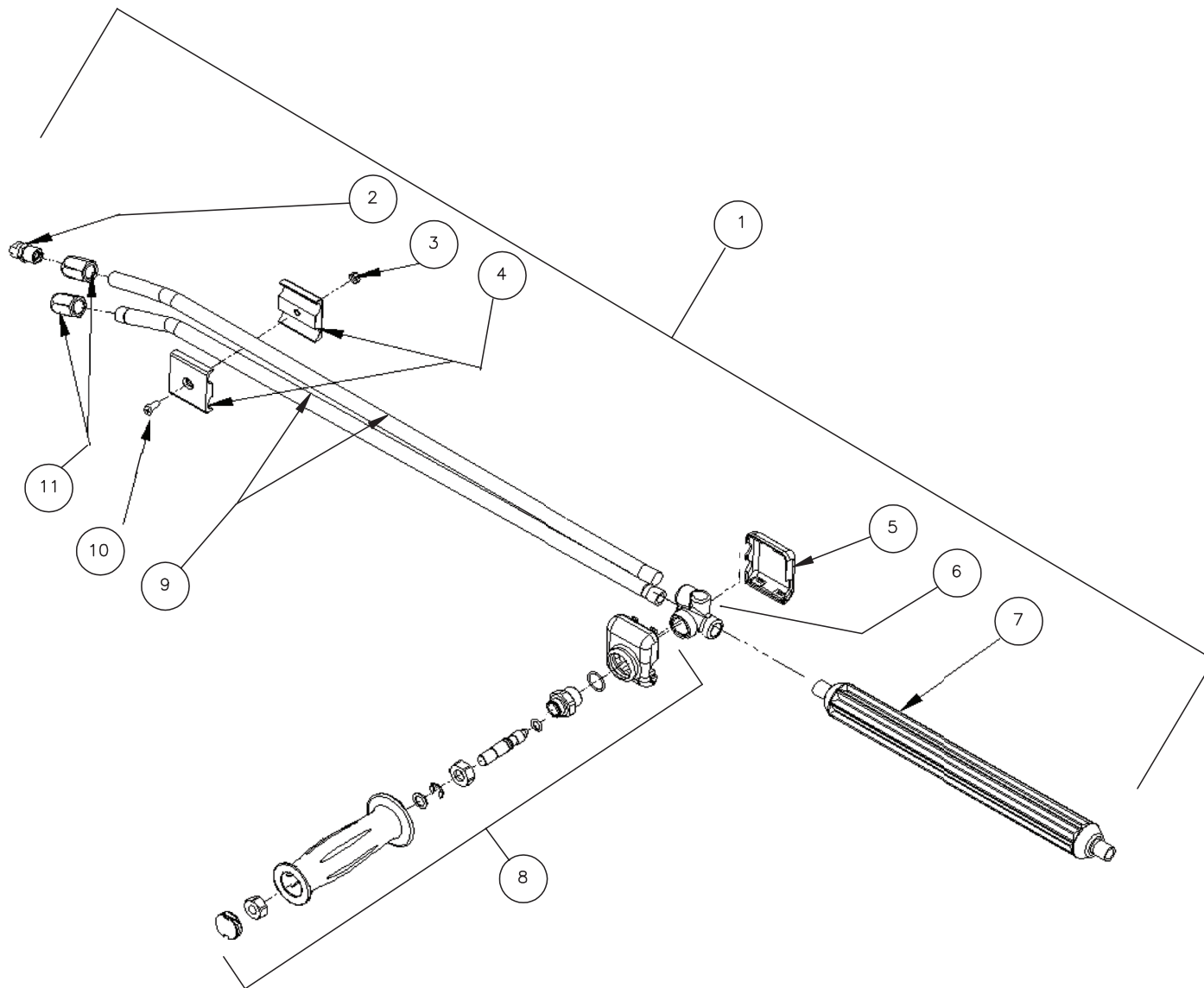

16-0416\_16-0417-102405-RZ



<b>DUAL LANCE ASSEMBLY (16-0416 &amp; 16-0417)</b>			
<b>REF. #</b>	<b>DESCRIPTION</b>	<b>PART #</b>	<b>QTY.</b>
1	Dual Lance Assembly - 36" (Inc. 2-11)	16-0416	1
-	Dual Lance Assembly - 48" (Inc. 2-11)	16-0417	1
2	Detergent Nozzle	18-0110	1
3	Nut	30-6001	1
4	Clamp	16-0420	2
5	Lower Valve Cover (See 16-0416 or 16-0417)	N/A Sep.	1
6	Housing (See 16-0416 or 16-0417)	N/A Sep.	1
7	Lance	16-0419	1
8	Handle Repair Kit	70-0419	1
9	Lance (See 16-0416)	N/A Sep.	2
-	Lance (See 16-0417)	N/A Sep.	2
10	Screw	27-8196	1
11	Nozzle Adapter	24-0280	2

# WIRING SCHEMATIC

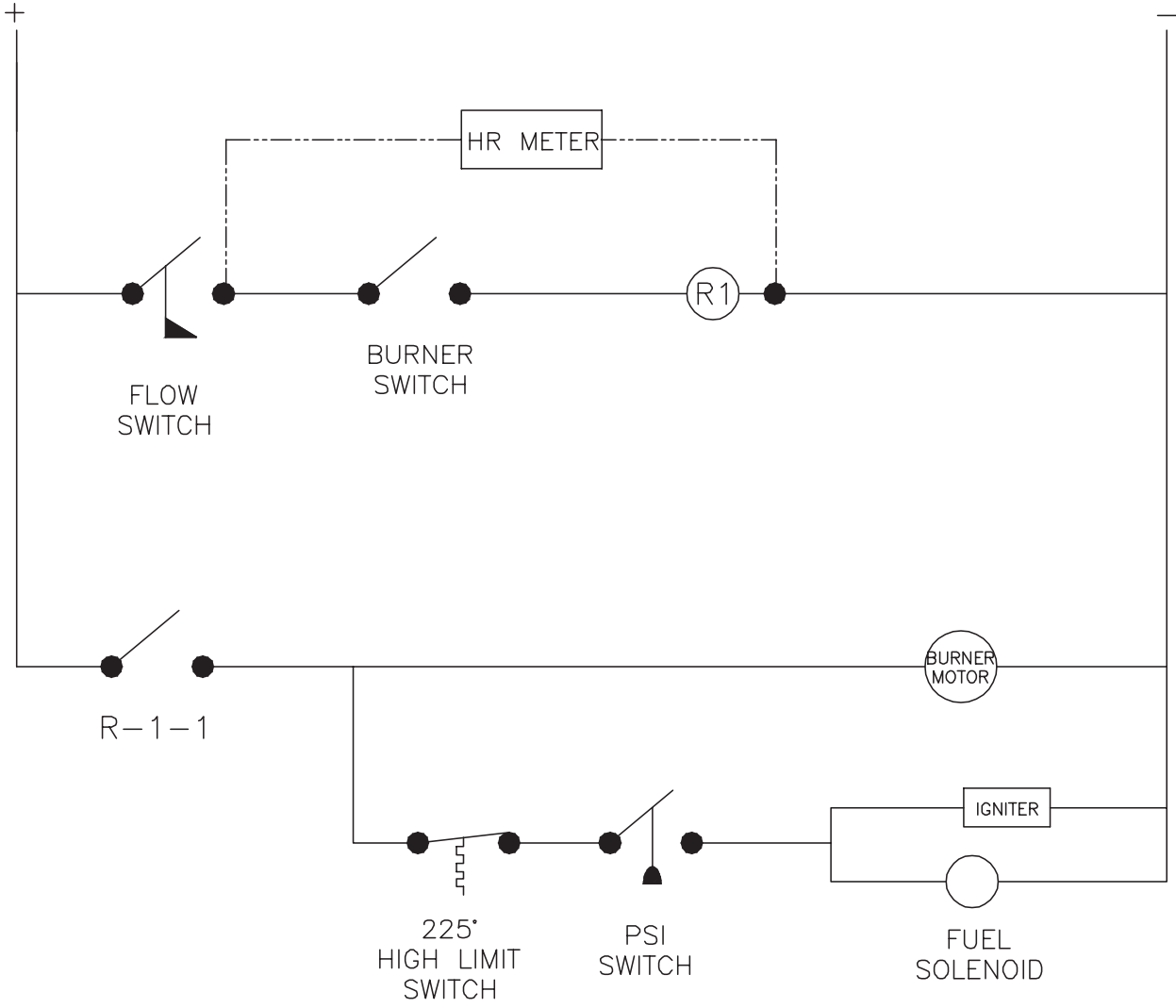

HDC WIRE SCHEMATIC-06203-KZ

# WIRING DIAGRAM

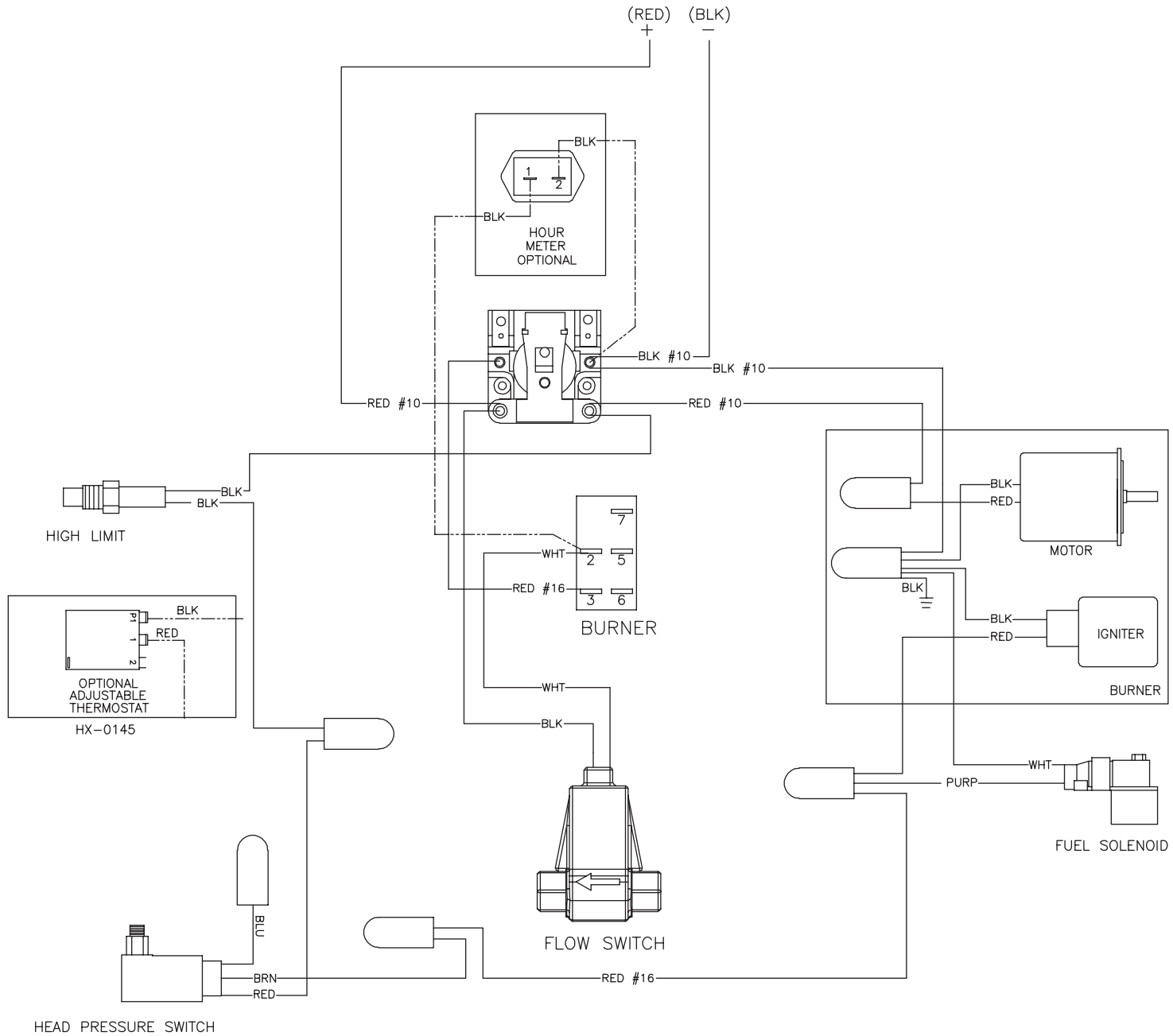

HDC WIRE DIAGRAM-060203-KZ

### 3-WAY BALL VALVE OPTION (HX-0130)

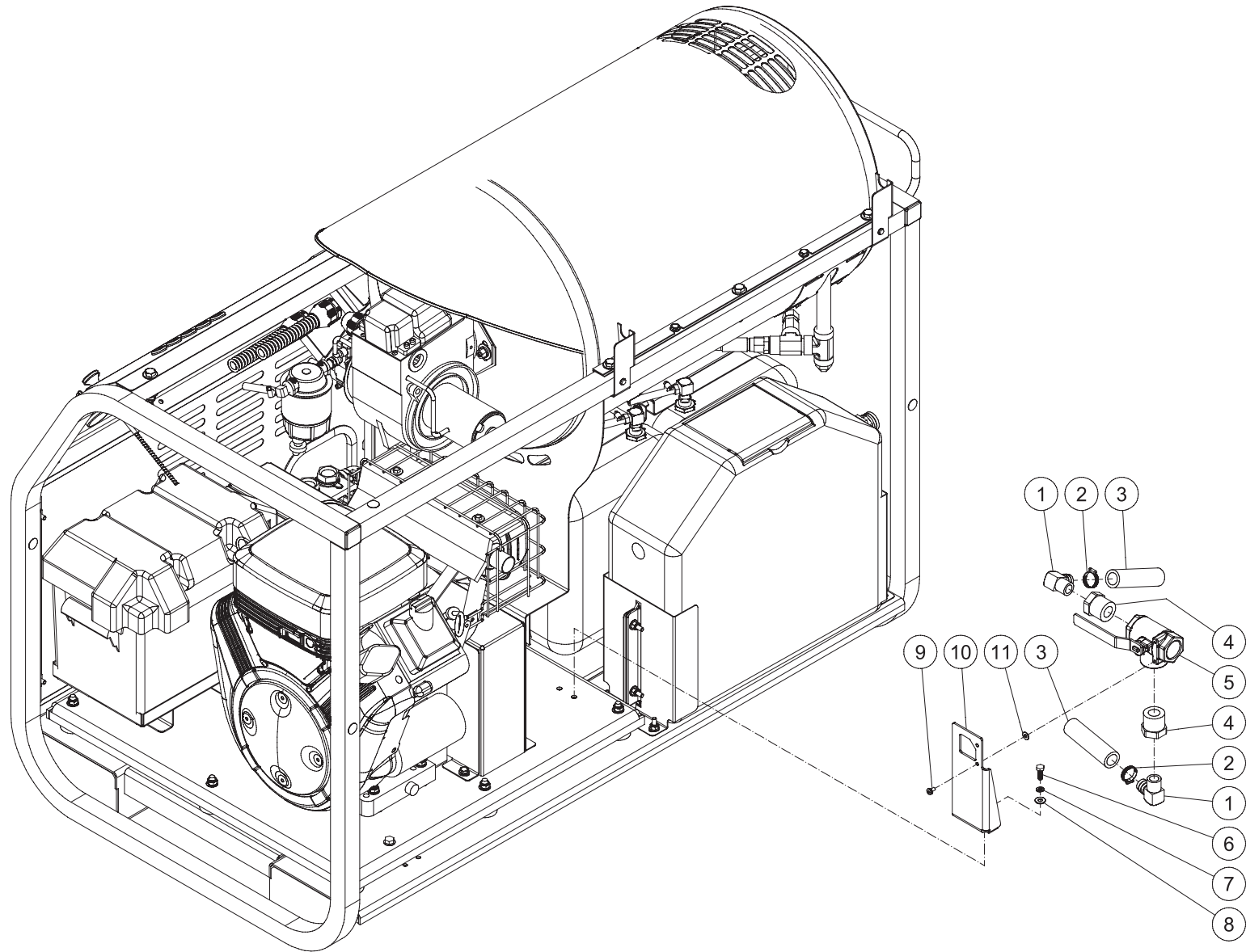

HX-0130 3-WAY BALL VALVE OPTION-121709-CH

HX-0130-3 WAY BALL VALVE OPTION 121709-CH			
3 WAY BALL VALVE (HX-0130)			
ITEM	DESCRIPTION	Mi-T-M #	QTY
1	ELBOW	23-0037	2
2	HOSE CLAMP	42-0003	2
3	HOSE *(TWO FEET REQUIRED)	15-0033	2
4	REDUCER	23-0226	2
5	BALL VALVE	22-0321	1
6	BOLT	27-0015	2
7	LOCKWASHER	29-0006	2
8	WASHER	28-0002	2
9	SCREW	27-9533	2
10	BRACKET	20-0560A01	1
11	WASHER	28-0001	2
*MUST ORDER IN ONE FOOT LENGTHS			

## TRAPPING UNLOADER OPTION (HX-0225)

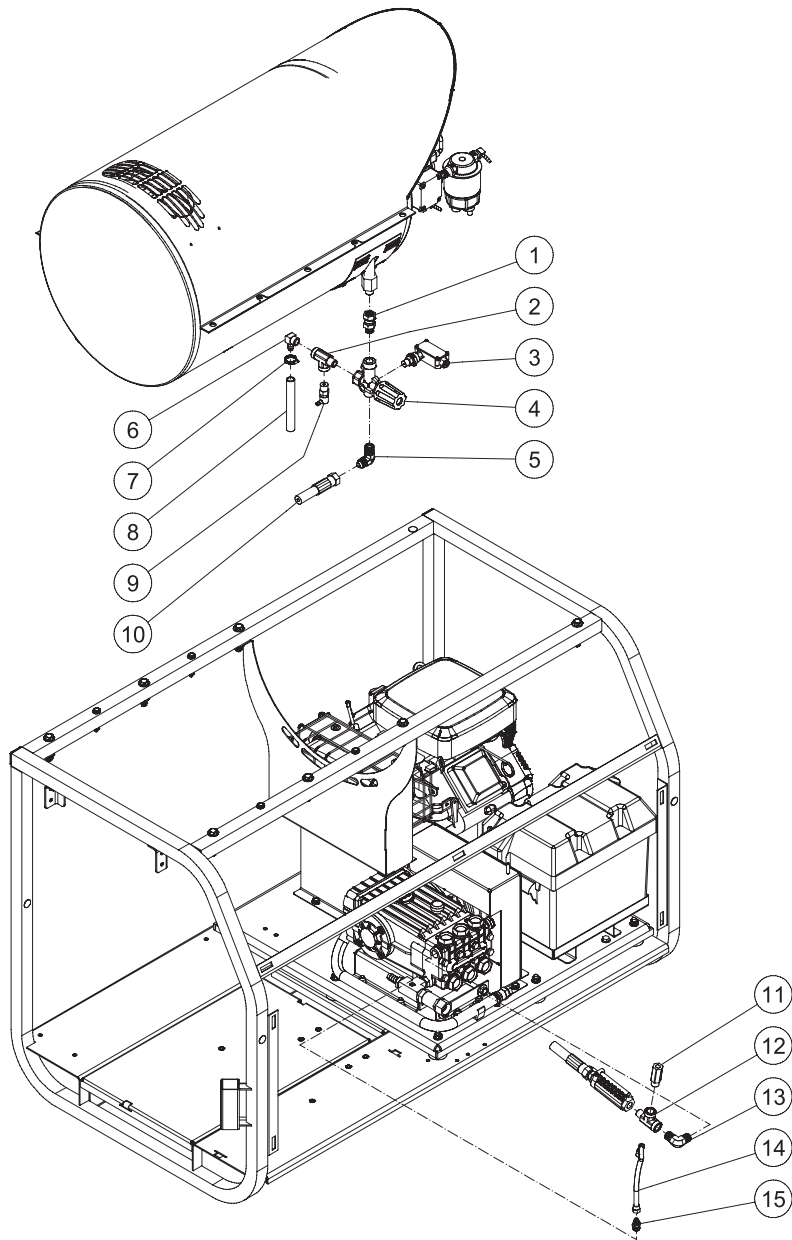

HX-0225 TRAPPING UNLOADER OPTION-122209-CH

HX-0225 TRAPPING UNLOADER 122209-CH			
TRAPPING UNLOADER (HX-0225)			
ITEM	DESCRIPTION	Mi-T-M #	QTY
1	SWIVEL	24-0037	1
2	STREET TEE	23-0058	1
3	PRESSURE SWITCH	22-0243	1
4	UNLOADER	850-0252	1
5	ELBOW	24-0092	1
6	ELBOW	23-0050	1
7	HOSE CLAMP	42-0011	1
8	HOSE *(TWO FEET REQUIRED)	15-0007	1
9	HEAT DUMP VALVE	22-0432	1
10	HIGH PRESSURE HOSE ASSEMBLY	15-0221	1
11	EASY START VALVE	22-0242	1
12	STREET TEE	23-0058	1
13	ELBOW	24-0131	1
14	EASY START HOSE	15-0140	1
15	NIPPLE	23-0247	1
*MUST ORDER IN ONE FOOT LENGTHS			

## CONTROL PANEL (HX-0156/0220/0221/0222/0224)

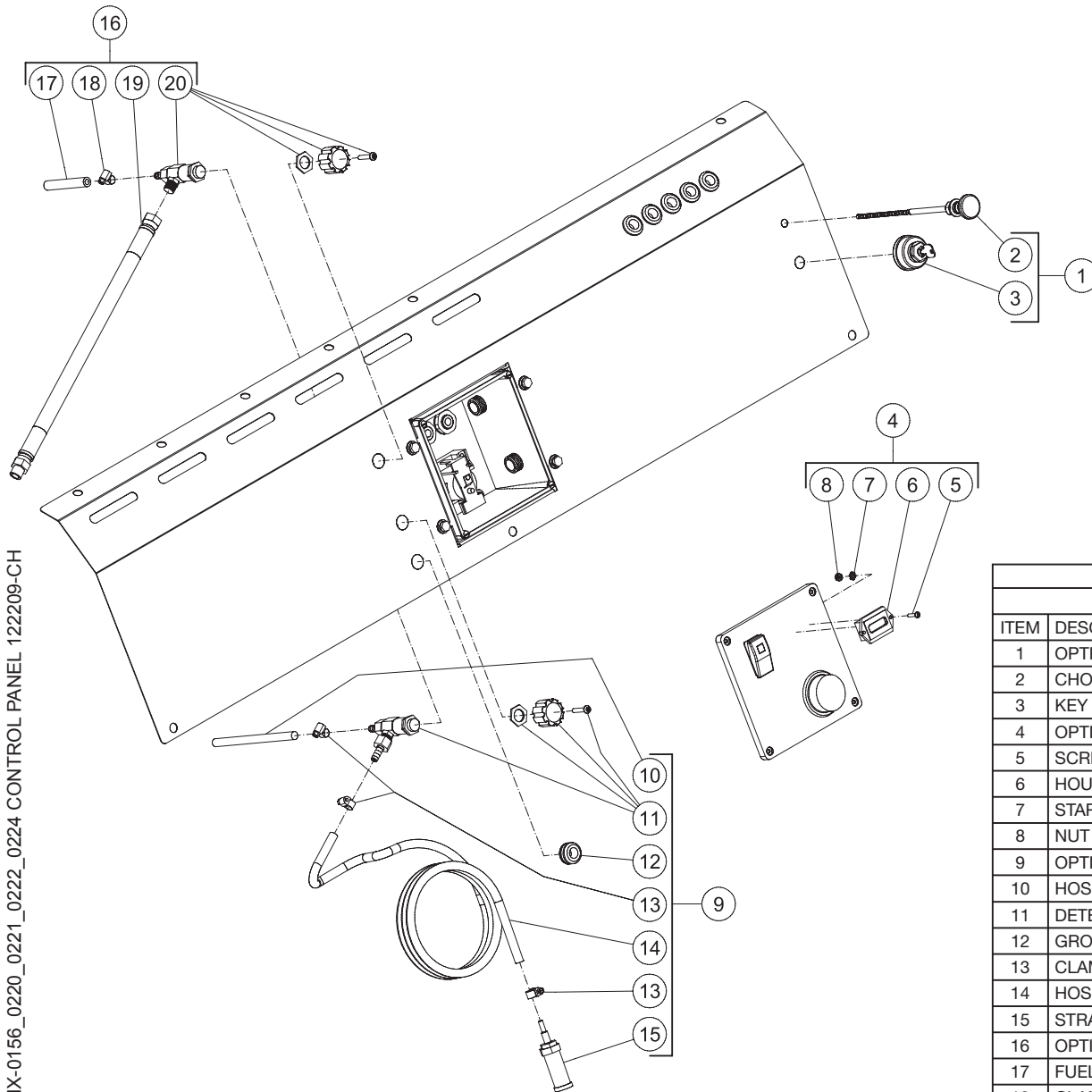

HX-0156\_0220\_0221\_0222\_0224 CONTROL PANEL 122209-CH

HX-0156/0220/0221/0222/0224 122209-CH			
CONTROL PANEL (HX-0156/0220/0221/0222/0224)			
ITEM	DESCRIPTION	Mi-T-M #	QTY
1	OPTION - PANEL KEYSWITCH (INC. 2-3)	HX-0222	-
2	CHOKE CABLE	33-0081	1
3	KEY SWITCH (SEE ENGINE BREAKDOWN)	-	1
4	OPTION - HOUR METER (INC. 5-8)	HX-0156	-
5	SCREW	27-8881	2
6	HOUR METER	32-0431	1
7	STAR WASHER	28-1009	2
8	NUT	30-0052	2
9	OPTION - FLOAT TANK W/ CHEMICAL (INC. 10-15)	HX-0220 HX-0221	
10	HOSE *(TWO FEET REQUIRED)	15-0079	1
11	DETERGENT VALVE	22-0226	1
12	GROMMET	33-0001	1
13	CLAMP WORM	42-0004	3
14	HOSE *(SIX FEET REQUIRED)	15-0021	1
15	STRAINER	19-0056	1
16	OPTION - STEAM HDB-3005 (INC. 17-20)	HX-0224	-
17	FUEL HOSE *(TWO FEET REQUIRED)	15-0008	1
18	CLAMP WORM SS 1/4-5/8	42-0004	1
19	HIGH PRESSURE HOSE	15-0225	1
20	STEAM VALVE	22-0329	1

\*MUST ORDER IN ONE FOOT LENGTHS

# FLOAT TANK OPTION (HX-0220/0221)

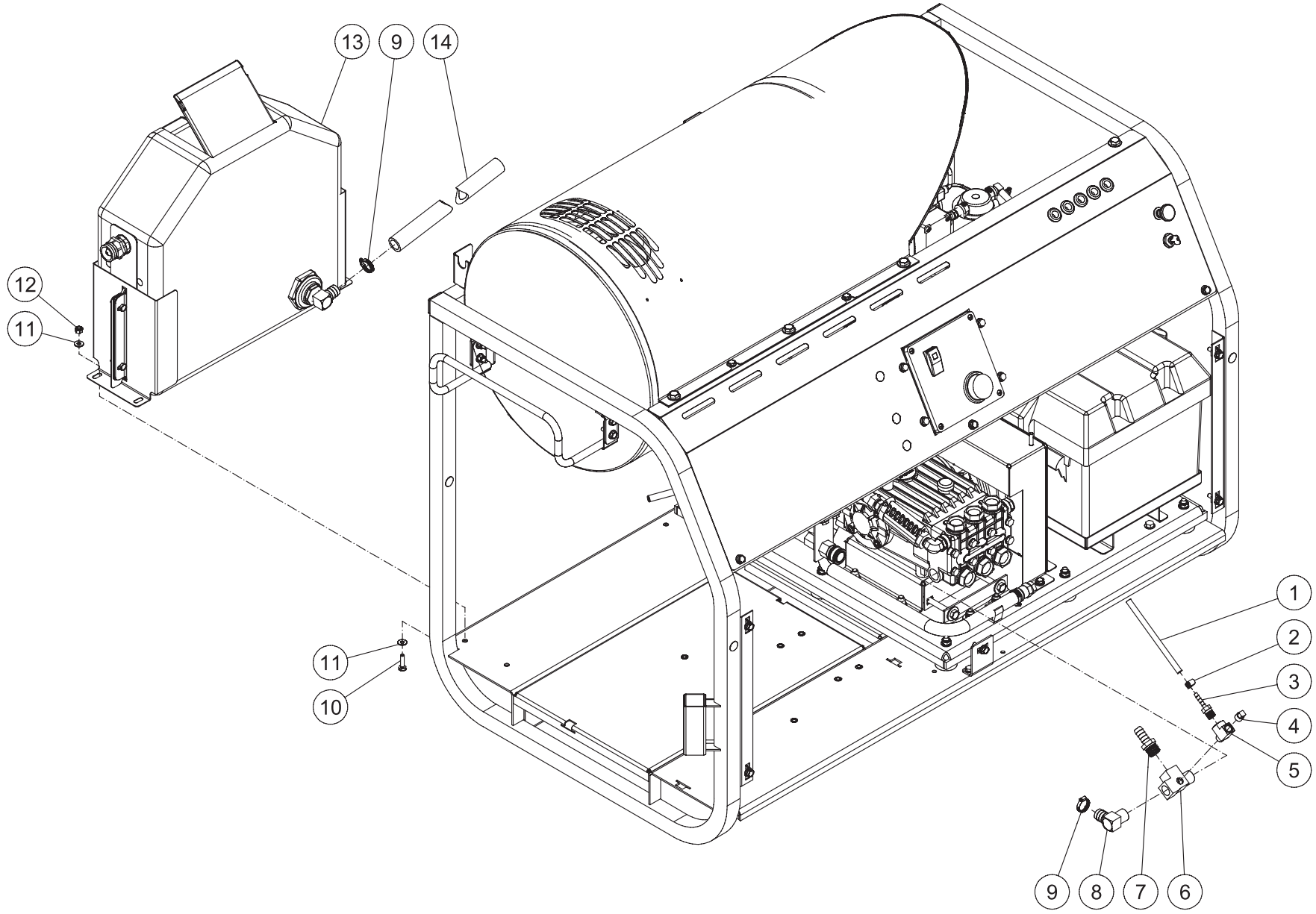

HX-0220/0221 FLOAT TANK OPTION 120209-CH



HX-0220/0221 FLOAT TANK OPTION 120209-CH			
FLOAT TANK OPTION (HX-0220/0221)			
ITEM	DESCRIPTION	Mi-T-M #	QTY
1	HOSE *(TWO FEET REQUIRED)	15-0079	1
2	CLAMP WORM	42-0004	1
3	BARB	23-0051	1
4	PLUG (HX-0220)	23-0238	1
-	NIPPLE (HX-0221)	23-0247	1
5	TEE	23-0127	1
6	STREET TEE	23-0388	1
7	BARB	23-0045	1
8	ELBOW	23-0037	1
9	HOSE CLAMP	42-0003	2
10	BOLT	27-0016	4
11	WASHER	28-0002	8
12	LOCKNUT	30-0155	4
13	FLOAT TANK ASSEMBLY	N/A	1
14	HOSE *(TWO FEET REQUIRED)	15-0033	1
*MUST ORDER IN ONE FOOT LENGTHS			

# FLOAT TANK ASSEMBLY

HDS FLOAT TANK ASSY 082809-CH			
FLOAT TANK ASSY			
ITEM	DESCRIPTION	PART #	QTY
1	LOCKNUT	30-0155	4
2	WASHER	28-0002	4
3	FLOAT TANK INLET BRACKET	20-0586A18	2
4	BRACKET	20-0912A18	1
5	BOLT	27-0016	4
6	LOCKWASHER	29-0074	1
7	FLOAT VALVE	22-0317	1
8	BALL FLOAT STUD	31-3320	1
9	FLOAT	22-0059	1
10	FLOAT TANK	N/A	1
11	BULKHEAD	55-0886	1
12	FLOAT TANK ASSEMBLY (INC. 10-11)	850-0322	1
13	ELBOW	23-0037	1
14	NIPPLE	23-0019	1
15	STRAINER	19-0203	1
16	LOCKNUT	23-0428	1
17	GARDEN HOSE INLET	23-0021	1
18	FILTER	19-0001	1

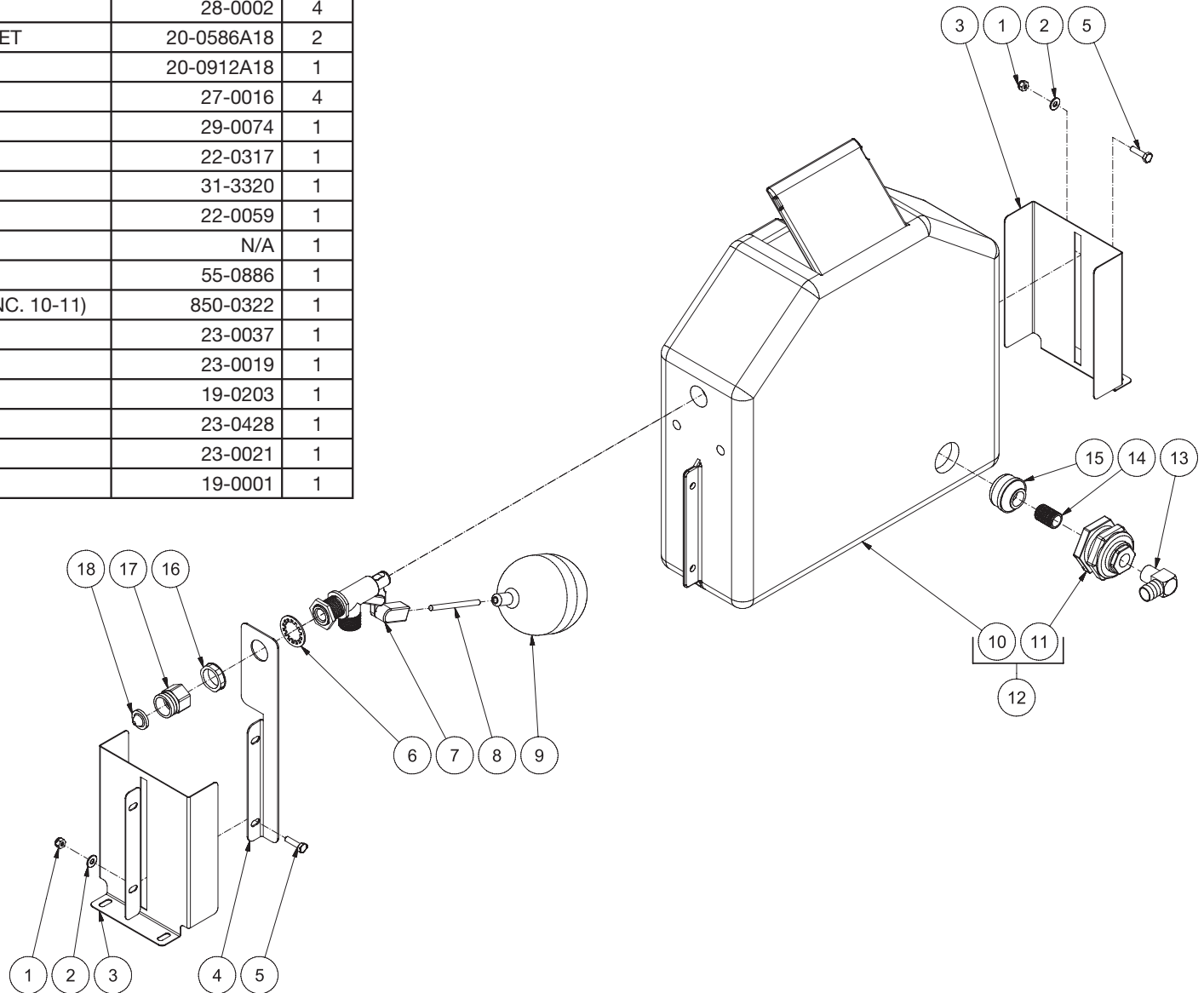

HDS FLOAT TANK ASSY-082809-CH

## STEAM OPTION PLUMBING (HX-0224)

HX-0224-STEAM OPTION PLUMBING 122209-CH			
STEAM OPTION PLUMBING (HX-0224)			
ITEM	DESCRIPTION	Mi-T-M #	QTY
1	BARB	23-0051	1
2	HIGH PRESSURE HOSE	15-0225	1
3	ELBOW	24-0131	1
4	REDUCER	23-0017	1
5	STREET TEE	23-0058	1

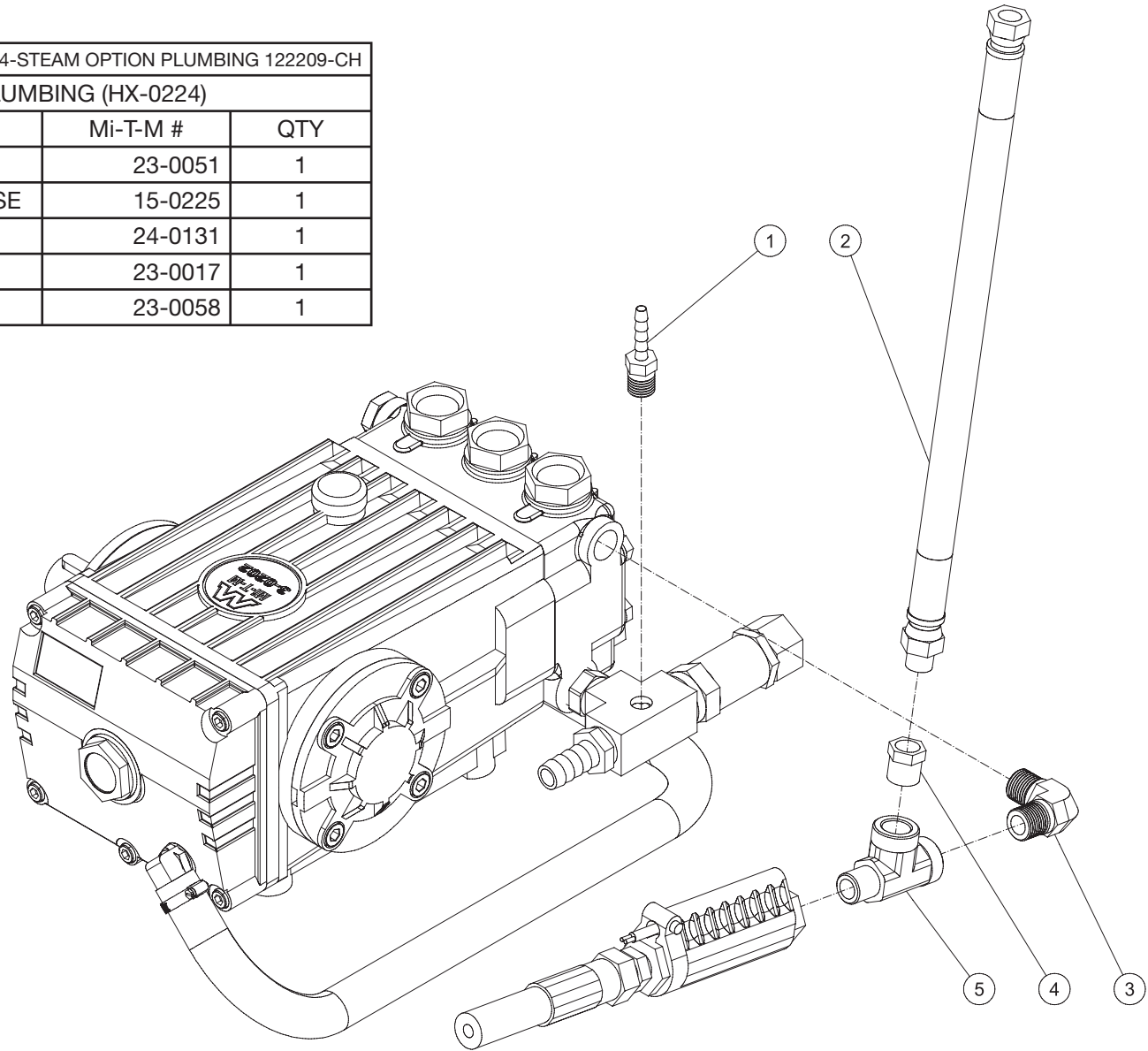

HX-0224-STEAM OPTION PLUMBING 122209-CH

Manufactured by Mi-T-M  
8650 Enterprise Drive, Peosta IA 52068  
563-556-7484/ Fax 563-556-1235